

FIRST AMENDMENT TO LEASE AGREEMENT

4600014770  
2018-0706

THIS FIRST AMENDMENT TO LEASE AGREEMENT ("First Amendment") is made and entered into by and between **MIDTOWN CENTRAL SQUARE, LLC.**, a Texas limited liability company ("Landlord"), whose address for purposes hereof is 5555 West Loop, South, Suite 100, Bellaire, Texas 77401; Attention: Keeley Megarity; and the **CITY OF HOUSTON, TEXAS**, a municipal corporation situated in Harris, Fort Bend and Montgomery Counties ("Tenant"), whose address for purposes hereof is P. O. Box 1562, Houston, Texas 77251, Attention: Director, General Services Department. Landlord and Tenant are also referred to collectively as the "Parties" and individually as the "Party".

**WITNESSETH:**

**WHEREAS**, Landlord and Tenant entered into a Lease Agreement ("Original Lease"), a copy of which is attached hereto as **Exhibit "A"**, passed and adopted by the City Council of Tenant by Ordinance No. 2018-153 on February 28, 2018, to provide for the rental and other costs associated with approximately 43,846 square feet of space located on floors nine (9) and ten (10) of 2100 Travis Street, Houston, Harris County, Texas 77002, with an option to lease additional space on all or part of floor four (4) ("Expansion Option"); and

**WHEREAS**, Tenant desires to exercise the Expansion Option in accordance with Section 1.1(k) of the Original Lease; and

**WHEREAS**, Tenant desires to share a portion of the space with its contractor(s) supporting Tenant's disaster recovery efforts; and

**WHEREAS**, Tenant also desires to increase the number of parking spaces, reserved and/or unreserved, and card keys for building access that Tenant is allowed under the Original Lease; and

**WHEREAS**, Tenant desires to make sure that its brokerage company is paid brokerage commissions by the Landlord; and

**WHEREAS**, the Parties desire to amend the Original Lease to reflect the exercise by Tenant of its Expansion Option, to share portion of the space with its contractor (s) supporting Tenant's disaster recovery efforts, to increase Tenant's allowable number of parking spaces/card keys and to guarantee payment by Landlord of brokerage commissions to Tenant's brokerage company under the Original Lease, as amended hereby;

**NOW, THEREFORE**, in recognition of the foregoing and in consideration of the mutual covenants and undertakings hereunder, the receipt and sufficiency of which are hereby mutually acknowledged, Landlord and Tenant agree as follows:

Tenant hereby exercises the Expansion Option under the Original Lease, as amended hereby, according to the following terms:

I.

**That the definition of "Leased Premises Expansion" be added to the Original Lease under Article 1, Section 1.1 to read as follows:**

A. "Leased Premises Expansion" means floor four (4) of the office building of the Project, approximately twenty one thousand nine hundred twenty three (21,923) square feet of net rentable space, as shown on **Exhibit "B-1"**, attached hereto and made part of the Original Lease, as amended hereby, together with all alterations, repairs, additions and improvements made pursuant to this First Amendment, including those shown on **Exhibit "D-1" and Exhibit "D-2"**, attached hereto and made a part of the Original Lease, as amended hereby.

B. Landlord shall build out the Leased Premises Expansion at Landlord's sole cost and expense pursuant to the work plan described in **Exhibit "D-2"**.

C. Landlord shall use its best efforts to have the Leased Premises Expansion ready for occupancy subject to Substantial Completion (minor punch list items) no later than March 1, 2019. If landlord has not completed the Tenant Improvements described in **Exhibit D-2** prior to March 1, 2019, Landlord shall be in default as described in Article 14 of the Lease and Tenant may complete the build out of the Leased Premises Expansion and deduct such costs from the Base Rent. In the event the Landlord presents Tenant build-out plans or related documents for review and approval during the build-out phase, Tenant shall respond within three (3) business days; and any failure to timely respond will extend the above deadline by the number of days Tenant exceeds such three (3) business days. Moreover, such date shall be further extended by one (1) day for each day of Delay.

D. Tenant shall occupy the Leased Premises Expansion for a Monthly Rate stated in Section 1.1(k) of the Original Lease, as amended hereby.

E. For the Leased Premises Expansion, Tenant's pro rata share of the Operating Expenses shall be calculated in accordance with Section 3.2(b) of the Original Lease, as amended hereby, which shall be 23.57percent.

F. For the Leased Premises Expansion, "Base Operating Expenses" shall be defined as the actual Operating Expenses incurred by Landlord for the calendar year of 2018 (subject to adjustment pursuant to Section 3.2(c) of the Original Lease, as amended).

G. Leased Premises Expansion shall be invoiced on monthly basis separately from the Premises subject to Original Lease.

II.

That Section 1.1 (h) of the Original Lease is hereby amended to read as follows:

- (h) "Permitted Uses" in regards to the expansion space means any and all uses as required for Tenant's Housing and Community Development Department and its Contractor(s) for general office purposes and for no other purpose without Landlord's prior written consent, which shall not be unreasonably withheld or delayed so long as the use is for general office purposes."

III.

That Section 4.3(b) of the Original Lease is hereby amended to read as follows:

"(b) Tenant shall notify Landlord no later than the last day of the twelve (12) month of the Lease of the number of parking spaces it desires whether reserved or unreserved. Landlord reserves the right, after thirty (30) days advance written notice to Tenant, to locate unreserved parking spaces in excess of two spaces per one thousand (2/1,000) square feet leased to a parking facility within two (2) blocks of the Project during the remainder of the Term. However, hundred twenty (120) unreserved parking spaces for the Premises shall remain in the garage. Total number of parking spaces for the Premises, whether reserved or unreserved, shall be one hundred twenty (120), unless otherwise agreed to by the parties in writing."

IV.

That Section 4.4 of the Original Lease is hereby amended to read as follows:

"Landlord shall provide at no cost to Tenant, in a good and workmanlike manner and in accordance with all applicable law, a building card key access system for entry into the Project and entry door to the Leased Premises and the Leased Premises Expansion. Landlord shall provide Tenant with a total of 230 card keys at no cost to Tenant; additional card keys shall cost Tenant \$2.00 for each card key."

V.

That Article 20, Brokerage, of the Original Lease is hereby amended to read as follows:

"ARTICLE 20. Brokerage and Offset Right. Landlord will pay in full a brokerage commission to Tenant's designated broker Cushman & Wakefield of Texas, Inc. and Landlord's designated broker

Transwestern, under a separate commission agreement. In the event Landlord fails to pay in full such brokerage commission to Cushman & Wakefield under the Original Lease, as amended, Tenant may, upon written notice to Landlord, deduct the amount due to Cushman & Wakefield from Tenant's Monthly Rent payments and /or Tenant Improvement Payment under the Original Lease and pay such amounts to Cushman & Wakefield, until such time as the full amount due and owing by the Landlord to Cushman & Wakefield is satisfied.

Further, Tenant shall have the right to offset from Tenant's Monthly Rent any amounts due and owing to the City of Houston by the Landlord under the Original Lease, this First Amendment or any other agreement between the Tenant and the Landlord, its officers or affiliates from amounts due and owing to the Landlord by the Tenant under the Original Lease and this First Amendment, after a written notice to the Landlord."

#### **VI.**

That all references to Leased Premises in the Original Lease, as amended hereby, shall also include Leased Premises Expansion.

#### **VII.**

That no other changes are hereby made or intended to be made to the Original Lease, as amended hereby, and, except as herein specifically amended, the Original Lease, shall remain in full force and effect in accordance with the terms and provisions thereof and this First Amendment is hereby ratified and confirmed.

#### **VIII.**

That in case of any conflict or inconsistency between the terms and provisions of the Original Lease, as amended hereby, and the terms and provisions of this First Amendment, the terms and provisions of this First Amendment shall control.

#### **IX.**

The Parties have executed this First Amendment in multiple copies, each of which is an original. Each person signing this First Amendment represents and warrants that he or she is duly authorized and has legal capacity to execute and deliver this First Amendment. Each Party represents and warrants to the other that the execution and delivery of this First Amendment and the performance of such Party's obligations hereunder have been duly authorized and that this First Amendment is a valid and legal agreement binding on such Party and enforceable in accordance with its terms and provisions.

***(Remainder of this page is intentionally left blank)***  
***(Signatures are on the following pages)***

EXECUTED in multiple counterparts, dated as of the date of countersignature by the City Controller, and to be effective upon the Lease Effective Date.

“LANDLORD”

**MIDTOWN CENTRAL SQUARE,  
LLC.**, a Texas limited liability  
company

By:   
Name: Kelley Megarity  
Title: managing member  
Tax ID No. 46-2092060

***[Execution page for Tenant on following page]***

"TENANT"

ATTEST:



Anna Russell  
City Secretary

CITY OF HOUSTON, TEXAS



Sylvester Turner  
Mayor

APPROVED AND RECOMMENDED:

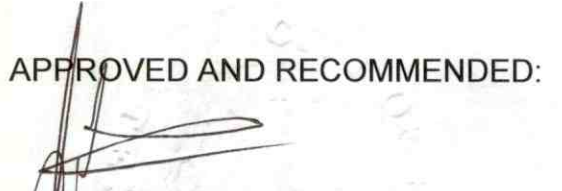

Richard A. Vella, Assistant Director  
of Real Estate, Design & Construction,  
General Services Department



C.J. Messiah, Jr.  
Director, General Services Department

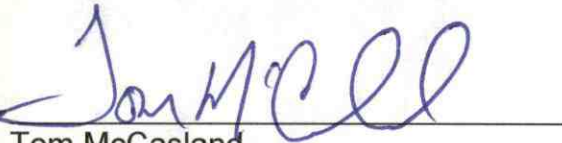

Tom McCasland  
Director, Housing and Community  
Development Department

APPROVED AS TO FORM:



Alice Adam  
Senior Assistant City Attorney  
LD # 0331700069002

COUNTERSIGNED:



Chris B. Brown  
Controller

Countersignature Date:

9-13-18

**Exhibit "A"**

Original Lease

4600014770  
2018-0153

## LEASE AGREEMENT

THIS LEASE AGREEMENT (this "Lease") is made and entered into by and between **MIDTOWN CENTRAL SQUARE, LLC.**, a Texas limited liability company ("Landlord"), whose address for purposes hereof is 5555 West Loop, South, Suite 100, Bellaire, Texas 77401; Attention: Keeley Megarity; and the **CITY OF HOUSTON, TEXAS**, a municipal corporation situated in Harris, Fort Bend and Montgomery Counties ("Tenant"), whose address for purposes hereof is P. O. Box 1562, Houston, Texas 77251, Attention: Director, General Services Department.

### ARTICLE 1.

#### Certain Definitions, Basic Provisions and Cross References

Section 1.1 The following definitions, basic provisions and cross references are placed at the beginning of this Lease for easy reference to certain material terms and provisions of this Lease. Landlord and Tenant hereby agree that each and every provision contained in this Lease is material to the agreements between Landlord and Tenant relating to the Leased Premises (hereinafter defined), and no implication is intended, nor shall any implication be inferred, that the failure to define or reference a term, provision, covenant, agreement or condition in this Article 1 shall mean that such term, provision, covenant, agreement or condition is not material or an integral part of this Lease. This Lease should be read carefully and in full for all the terms, provisions, covenants, agreements and conditions that are material to the intent and agreements of the parties under this Lease.

- (a) "Project" means the land, together with the office building located thereon and any improvements, common areas and parking facilities thereon located and having a street address of 2100 Travis, Houston, Harris County, Texas 77002, and as shown on **Exhibit "A"**, attached and made a part of this Lease.
- (b) "Leased Premises" means (i) floors nine (9), and ten (10) of the office building of the Project, each floor being approximately 21,923 square feet for a total of approximately 43,846 square feet of net rentable square feet of space out of the Project and (ii) the parking facilities adjacent to and in front of the building, as shown on **Exhibit "B"**, attached and made a part of this Lease, together with all alterations, repairs, additions and improvements made pursuant to this Lease, including those shown on **Exhibit "D"**, attached and made a part of this Lease, such space being commonly known by its mailing address of 2100 Travis, Houston, Texas 77002.
- (c) "Occupancy Date" means the earlier of: (i) the date Tenant conducts regular business in the Leased Premises, (ii) the date that is five (5) days after the date of Substantial Completion (hereinafter defined in the Work Letter) of the Leased Premises, or (iii) the date that Substantial Completion of the Leased Premises would have occurred but for Delay (hereinafter defined in



the Work Letter), calculated by subtracting the number of days of Delay from the actual date of Substantial Completion. Landlord and Tenant estimate that Substantial Completion of the Leased Premises will occur on January 2, 2019. Notwithstanding anything to the contrary in this Lease, if Substantial Completion of the Leased Premises occurs prior to February 1, 2019, Tenant may elect, by delivering written notice of the same to Landlord, to occupy the Leased Premises (the "Early Occupancy") as of such prior date. During any Early Occupancy, Tenant shall be subject to all of the terms and conditions of this Lease, except that Tenant shall not be obligated to pay Rent. Landlord and Tenant agree to execute the Certificate of Commencement, in the form attached and made a part of this Lease as **Exhibit "C"**, as soon as reasonably practical after the Occupancy Date.

- (d) "Lease Term" means ten (10) years commencing on February 1, 2019, for floors nine (9) and ten (10), unless sooner terminated or extended pursuant to the terms of this Lease subject to Section 1.1(e) hereof.
- (e) "Lease Effective Date" means the date of countersignature by the City Controller, provided that Landlord has already affixed its signature to the Lease before Tenant's signature is affixed. Tenant acknowledges and agrees that (i) Landlord's affixation of its signature to this Lease and delivery of the same to Tenant shall constitute an offer to lease the Leased Premises to Tenant on the terms and conditions contained in this Lease, and (ii) if Tenant fails to cause the Lease Effective Date to occur within thirty (30) days after Tenant's receipt of the same, Landlord shall have the right to withdraw such offer upon delivering written notice of such withdrawal to Tenant.
- (f) "Monthly Rent" means the following amount due to Landlord each calendar year during the Lease Term, payable monthly and is based on the rental rate based on square footage measurement of the Leased Premises as follows:

**Floors 9 and 10 (43,846 Sq. Ft. of net rentable area)**

Years	Full Service Gross Rent/SF/Year	Monthly Rent
1	\$11.50	\$42,019.08
2	\$22.00	\$80,384.33
3	\$22.50	\$82,211.25
4	\$23.00	\$84,038.16
5	\$23.50	\$85,865.08
6	\$27.00	\$98,653.50
7	\$27.50	\$100,480.41
8	\$28.00	\$102,307.33

9	\$28.50	\$104,134.25
10	\$29.00	\$105,961.16

- (g) "Additional Rent" shall mean that, in addition to the Monthly Rent, Tenant shall pay to the Landlord "Operating Expenses" (as further described in Section 3 below and in **Exhibit "E"**, attached hereto and incorporated for all purposes). Monthly Rent, Operating Expenses and any other amounts to be paid by Tenant under the terms of this Lease shall be referred to collectively as "Rent."
- (h) "Permitted Uses" means any and all uses as required for Tenant's Housing and Community Development Department for general office purposes and for no other purpose without Landlord's prior written consent, which shall not be unreasonably withheld or delayed so long as the use is for general office purposes.
- (i) "Hours of Operation" shall mean 7:00 a.m. to 7:00 p.m. on Mondays through Fridays; and 7:00 a.m. to 1:00 p.m. on Saturdays; and excluding New Year's Day, Memorial Day, Independence Day, Labor Day, Thanksgiving Day and Christmas Day and any other holidays officially observed by the City of Houston.
- (j) "Renewal Term" means Tenant shall have two (2) options to renew this Lease for two (2) additional five-year terms at the then prevailing Market Rate (hereinafter defined), subject to Section 3.4 in this Lease for floors nine (9) and ten (10).
- (k) "Expansion Option" means Tenant shall have twelve (12) months from the Lease Effective Date to exercise the Expansion Option for all or a portion of the fourth (4<sup>th</sup>) floor of the Project at the below rental rates.

Years	Full Service Gross Rent/SF/Year
1	\$24.50
2	\$25.00
3	\$25.50
4	\$26.00
5	\$26.50

In Tenant's notice to Landlord in exercising the Expansion Option, Tenant shall request the desired number of square feet of the 4<sup>th</sup> floor it desires to lease, and Landlord will identify and select the location and configuration of the space to be leased to Tenant on the 4<sup>th</sup> Floor based on the square footage requested by Tenant.

In addition, Tenant shall have the option to extend the term of the lease of the Floor 4 space under the Expansion Option under the following rental rates for a period of either a two (2) or five (5) year term that is to be selected at the sole discretion of the Tenant by written notice to Landlord at the time of exercising the Expansion Option. The Rent during the Renewal Term for the lease of the Floor 4 space under the Expansion Option shall be based on dollars per square foot as set forth below:

Year 1 of Renewal	\$24.00 RSF per year
Year 2 of Renewal	\$24.50 RSF per year
Year 3 of Renewal	\$25.00 RSF per year
Year 4 of Renewal	\$25.50 RSF per year
Year 5 of Renewal	\$26.00 RSF per year

- (l) "Work Letter" shall mean the letter between Landlord and Tenant concerning build-out of the Leased Premises, such letter to be substantially in the form of **Exhibit "D-1"** attached hereto and incorporated herein.

## **ARTICLE 2.** **Granting Clause**

Landlord hereby demises and leases to Tenant, and Tenant hereby rents, accepts and takes from Landlord, the Leased Premises TO HAVE AND TO HOLD said Leased Premises for the Lease Term, all upon the terms, provisions, covenants, agreements and conditions set forth in this Lease.

## **ARTICLE 3.** **Rent; Operating Expenses; Expansion Option**

Section 3.1 Tenant agrees to pay to Landlord each month during the Lease Term, without demand (except as expressly provided in Section 3.2), deduction or offset, the Rent. The first Rent payment shall commence on February 1, 2019. Subsequent Rent payments shall be due and payable on the first (1st) day of each calendar month during the Lease Term. Rent payments shall be prorated for any partial month. NO SECURITY DEPOSIT SHALL BE REQUIRED FROM TENANT.

### Section 3.2

(a) "Base Operating Expenses" shall be defined as the actual Operating Expenses incurred by Landlord for the calendar year of 2018 (subject to adjustment pursuant to Section 3.2(e)). Notwithstanding anything contained herein to the contrary, the Base Operating Expenses shall never be lower than \$10.00 per rentable square foot per year. "Operating Expenses" shall be defined as all reasonable costs, charges, and expenses incurred directly by Landlord with respect to operating, repairing, landscaping, maintaining, managing, and insuring the Project, as determined on an accrual basis by Landlord's accountant in accordance with generally accepted accounting principles, consistently applied, which shall include, but not be limited to, the heating, cooling,

ventilation, electrical, lighting, water, and plumbing systems serving the Project, insurance, the costs of maintenance and service agreements maintained on such systems, the costs for those services to be provided by Landlord pursuant to Article 9, the cost of alarm service, the cost of supplies and materials associated with any of the activities described herein, and all accounting, legal, and administrative costs (except as outlined in **Exhibit "E"**) of the Project. Except for the amortization charges outlined in **Exhibit "E"** attached hereto and incorporated herein, Operating Expenses shall not include any equipment Landlord installs in or improvements or alterations Landlord makes to the Project that would be considered capital improvements under generally accepted accounting principles. Operating Expenses shall also include "Real Estate Taxes," which shall be defined as all real estate taxes and installments of special and annual assessments (as well as any interest due), attributable to the respective Lease Year, which apply to the Project, including but not limited to the Texas Margin Tax; all personal property taxes which apply to the personal property located in the Project used in connection with the operation and maintenance thereof; and all other governmental charges, general and special, ordinary and extraordinary, foreseen as well as unforeseen, of any kind and nature whatsoever, or other tax, however described, levied or assessed by the United States of America, the State of Texas, or any political subdivision thereof, including county, municipal, or school district taxes, against Landlord for all or any part of the Project. If any assessments are payable in installments and Landlord elects to pay them in installments, Real Estate Taxes for such year shall include only those installments, plus any interest due thereon, attributable to the respective Lease Year. Real Estate Taxes shall also include any reasonable expenses, including legal fees and court costs, incurred in protesting or challenging any Real Estate Taxes. Notwithstanding the foregoing, Real Estate Taxes shall not include penalties, interest, or late charges assessed for failure to timely pay taxes, any net income tax, estate tax, or inheritance tax. Operating Expenses shall also include the costs of (a) capital improvements and/or structural repairs or replacements made in or to the Project (herein "Capital Improvements"), (b) the costs incurred by Landlord to install a new or replacement capital item for the purpose of reducing Operating Expenses (herein "Cost Savings Improvements"), and (c) a reasonable reserve for all other capital improvements and structural repairs and replacements reasonably necessary to permit Landlord to maintain the Project in its current class. The expenditures for Capital Improvements and Cost Savings Improvements shall be amortized over the useful life of such capital improvement or structural repair or replacement (as determined by Landlord). All costs so amortized shall bear interest on the unamortized balance at the rate of twelve percent (12%) per annum or such higher rate as may have been paid by Landlord on funds borrowed for the purpose of construction these capital improvements. Notwithstanding any other provisions contained in this Lease, Operating Expenses shall include management fees up to a maximum of three and half percent (3.5%) of the gross revenues of the Project. Notwithstanding any other provisions contained in this Lease, Operating Expenses shall not include (1) any replacements of the roof, walls, floor slab and structural components unless the replacement of such item is made in order to conform to changes, subsequent to the date of this Lease, in any applicable laws, and (2) the exclusions set forth on the exclusion list attached hereto and incorporated herein as **Exhibit "E"**. The management fee shall be set and fixed in the Base Operating Expenses. Landlord shall continue to maintain complete, accurate, and detailed books and records of Operating Expenses as

it has during its ownership of the Project. Tenant shall not be responsible to pay Tenant's Pro Rata Share of Operating Expenses during the first twelve (12) months of the Lease Term.

(b) "Tenant's Pro Rata Share" means fifteen and 72/100 percent (15.72%) share of the Operating Expenses for the applicable Lease Year based on the square footage of the Leased Premises and means the applicable percentage share (as reasonably determined by Landlord) of the Operating Expenses for the applicable Lease Year based on the square footage of the Floor 4 space for the Expansion Option as determined after the exercise of the Expansion Option. Anything herein to the contrary notwithstanding, it is agreed that in the event the Project is not fully occupied during any Lease Year (including 2018), a reasonable and equitable adjustment shall be made by Landlord in computing the Operating Expenses for such year so that the Operating Expenses (including assessed real estate taxes based on 100% occupancy) are a reasonable approximation of the amount that would have been incurred had the Project been fully occupied during the entirety of such year. Notwithstanding the foregoing, Controllable Operating Expenses shall not increase by more than three percent (3%) (on a cumulative and compounding basis) each year during the Term of the Lease. Landlord agrees that it will utilize a consistent methodology year to year in making such adjustments and, upon Tenant's request, will provide a reasonably detailed explanation of the adjustment made to Real Estate Taxes and to each component of Operating Expenses adjusted by Landlord. Controllable Operating Expenses are expenses within the reasonable control of Landlord thus excluding, without limitation, Ad Valorem taxes, building insurance, Tenant specific utilities and government-mandated increases in minimum wage. Non-controllable expenses shall be limited to Tenant's Pro Rata Share and capped at an increase of six percent (6%) per annum, cumulative and compounded.

(c) Beginning in calendar year 2019, and every Lease Year thereafter, Tenant shall pay Landlord the amount which Landlord estimates as Tenant's Pro Rata Share of Operating Expenses in excess of Base Operating Expenses for each Lease Year ("Additional Rent"). Further, Tenant shall also pay as Additional Rent any tax or excise on rents, gross receipts tax, or other tax, however described, which is levied or assessed by the United States of America, the State of Texas, or any political subdivision thereof, on the payment of or receipt of the Rent, reserved under this Lease; provided, however, that Tenant shall have no obligation to pay Landlord's net income taxes. The amount Landlord has estimated as Additional Rent shall be payable in equal monthly installments, in advance, on the first day of each month over the balance of the Lease Year, with the number of installments being equal to the number of full calendar months in such Lease Year.

(d) From time to time during any applicable Lease Year, if Landlord has a reasonable basis to believe that Real Estate Taxes and excess Operating Expenses for such Lease Year will be materially more or less than previously estimated by Landlord (however, not more than two times during any applicable Lease Year), Landlord may re-estimate the amount of Operating Expenses, and in such event Landlord shall notify Tenant, in writing, of such re-estimate and fix monthly installments of Additional Rent for the then remaining balance of such Lease Year in an amount sufficient to pay the

re-estimated amount over the balance of such Lease Year after giving credit for payments made by Tenant on the previous estimate.

(e) As to each Lease Year, Landlord shall estimate for each such Lease Year:

(i) the total amount of Operating Expenses in excess of Base Operating Expenses;

(ii) Tenant's Pro Rata Share of Operating Expenses in excess of Base Operating Expenses; and

(iii) The computation of the Rent payable during such Lease Year. Said estimate shall be in writing and shall be delivered or mailed to Tenant at the Leased Premises.

(f) Upon completion of each Lease Year, Landlord shall cause its accountants to determine the actual amount of Operating Expenses for such Lease Year and deliver a written certificate of the amounts thereof to Tenant. Landlord shall use commercially reasonable efforts to deliver such certificate to Tenant within one hundred eighty (180) days after the end of each Lease Year. If for any Lease Year Tenant has paid less than its Pro Rata Share of Operating Expenses in excess of Base Operating Expenses, Tenant shall pay the balance of its Additional Rent within fifteen (15) days after the receipt of such certificate. If for any Lease Year Tenant has paid more than its Pro Rata Share of Operating Expenses in excess of Base Operating Expenses, Landlord shall credit such excess against the most current monthly installment or installments due Landlord of Additional Rent, except that if an excess exists at the end of the Term, Landlord shall refund such excess to Tenant, less any amounts due and owing to Landlord under this Lease. In no event shall any adjustments as a result of this Article 2 result in Tenant paying less than the Base Rent in any Lease Year. A pro rata adjustment shall be made to Additional Rent for a fractional Lease Year occurring during the Term based upon the number of days of the Term during said Lease Year as compared to three hundred sixty-five (365) days, and all additional sums payable by Tenant or credits due Tenant as a result of the provisions of this Article 2 shall be adjusted accordingly when finally ascertained.

(g) If Tenant shall dispute any item or items included in the determination of Operating Expenses for a particular Lease Year, and such dispute is not mutually resolved by Landlord and Tenant within sixty (60) days after Tenant has given written notice to Landlord thereof, Tenant may request in writing to audit the books and records of Landlord relating to Operating Expenses; provided, however, unless Tenant shall complete said audit within one hundred twenty (120) days from the date of receipt of Landlord's year-end written certificate and make a claim for adjustment within one hundred eighty (180) days of the date of receipt of Landlord's year-end written certificate, Tenant shall forfeit its right to claim any adjustment to Tenant's pro rata share of Operating Expenses or Real Estate Taxes for such Lease Year.

(h) The audit will be conducted at Tenant's expense by a regionally or nationally recognized certified public accounting firm or a CPA (defined below) or by qualified personnel from Tenant's accounting office. Under no circumstance shall the audit be performed by a firm paid upon a contingency basis. If Tenant's audit reveals that the

Operating Costs charged to Tenant exceed or were less than Tenant's Proportionate Share of the actual Operating Costs (unless challenged by Landlord within ten (10) days after receipt of a complete copy of such audit), then Landlord will reimburse Tenant for any overcharge, or Tenant will pay to Landlord any undercharge, as applicable, promptly after such final determination. In the event of a confirmed overcharge of Operating Costs to Tenant in excess of five percent (5%) of Tenant's Proportionate Share of actual Operating Costs in any such year and Tenant's qualified personnel from its accounting office performed the audit, then a regionally or nationally recognized certified public accounting firm or a CPA must review and confirm such five percent (5%) overcharge. If a regionally or nationally recognized certified public accounting firm or a CPA confirms an overcharge of Operating Costs to Tenant in excess of five percent (5%) of Tenant's Proportionate Share of actual Operating Costs in any such year, Landlord also shall reimburse Tenant for the reasonable cost of Tenant's audit ("Audit Expense") up to three thousand five hundred and 00/100 dollars (\$3,500.00). If there is a dispute between Landlord and Tenant relating to the determination of whether or not there is an overcharge or undercharge relating to Operating Costs and the parties cannot in good faith resolve such issue within thirty (30) days, then Landlord and Tenant shall use reasonable efforts to agree, within ten (10) days following the expiration of such thirty (30)-day period upon the appointment of one (1) CPA to resolve the matter. If an agreement on a single CPA cannot be reached within the ten (10)-day period, Landlord and Tenant shall each appoint their own respective CPA within ten (10) business days following the elapse of the ten (10)-day period and shall specify the name and address of their respective CPA to the other party prior to the expiration of such ten (10)-business day period; provided, that if one party fails to specify the name and address of its selected CPA within such ten (10)-business day period, the other party shall give the failing party written notice and if within five (5) days after such written notice the failing party still has not specified a CPA, the CPA selected by the other party shall act as the single CPA as if both parties had agreed to the appointment of such CPA as provided above. The selected CPAs shall then meet within ten (10) days of the appointment of the last of the two, and if such CPAs are unable to agree upon such matter within fifteen (15) days, they shall appoint a third CPA within ten (10) business days following expiration of this period. If the two CPAs are unable to agree upon a third CPA within such ten (10)-business day period, the third CPA shall be appointed as soon as reasonably possible thereafter by the American Arbitration Association (or any successor organization, or if no successor organization shall then exist, by a court of competent jurisdiction residing in Harris County, Texas), subject to the qualification requirements set forth below. The term "CPA" shall mean a certified public accountant licensed in the State of Texas. The cost and expense incurred by the CPAs' review shall be borne equally by the parties.

Section 3.3 Landlord will invoice Tenant at the Leased Premises, Attention: Chief Operating Officer, Housing and Community Development Department (or such other person designated by Tenant in writing to Landlord), no later than the twenty-fifth (25th) day of each month for the Rent due and payable on or before the first (1st) day of the next succeeding month, to ensure the timely receipt of the Rent on or before the first (1st) day of each month. Notwithstanding anything contained in this Lease to the contrary, Landlord acknowledges and agrees that all Rent and any other payments payable to Landlord by Tenant shall be made only by warrant that must be a negotiable instrument

payable and/or wire transfer to Landlord's account as directed by Landlord by the first (1<sup>st</sup>) day of each month issued by the City of Houston City Controller within ten (10) days of receipt of an invoice by Tenant. Rent will be made payable to Landlord at 5555 West Loop South, Suite 100, Bellaire, Texas 77401, Attention: Keeley Megarity, or to such other address as Landlord may provide to Tenant in writing from time to time. Landlord hereby admits its knowledge and notice that the ability of Tenant to make Rent and any other payments payable to Landlord by Tenant is completely dependent upon and limited by the extent to which funds may be certified by the City of Houston City Controller as available for use in making Monthly Rents under this Lease. Notwithstanding the foregoing, provided Landlord has sent the required invoice, Tenant acknowledges that it will be in default of its obligations under this Lease if it has not tendered payment of the Rent on or before the first (1<sup>st</sup>) day of each month during the Lease Term. If Landlord fails to send the required invoice, Tenant shall not be relieved of any of its obligations or liabilities under this Lease, except that Tenant's obligation to pay the Monthly Rent applicable to such required invoice will be temporarily relieved until Landlord sends such required invoice, at which time such obligation shall be fully restored.

Section 3.4 Provided that Tenant is not in default of any of its obligations under this Lease, and by providing no less than twelve (12) or more than fifteen (15) months prior written notice, for floors nine (9) and ten (10), Tenant shall have two (2) options to renew this Lease for two (2) additional five (5) year terms (each a "Renewal Term") at the then current Market Rate. "Market Rate" shall be the then-prevailing fair market rental value rate (determined on a "gross" lease basis as of the exercising of the respective provision by Tenant) charged to tenants for space of comparable size and conditions, in comparable office buildings and locations in the area of Houston, Harris County, Texas located within a two (2) mile radius of the Project, taking into consideration the following: 1) location, quality and age of the building; 2) use, location, size and/or floor level(s) of the space in question, including view, elevator lobby exposure, etc.; 3) definition of "rentable" area with respect to which rental rates are computed; 4) extent of leasehold improvements in the premises (other than those in the Leased Premises paid for by Tenant) or to be provided, and/or any leasehold improvement allowance; 5) abatements (including with respect to the base rental, operating expenses and real estate taxes, and parking charges); 6) inclusion of parking charges in rental; 7) lease takeovers/assumptions; 8) programming/space, planning/interior, architecture and engineering allowances; 9) relocation allowance; 10) refurbishment allowances; 11) distinction between "gross" and "net" lease; 12) base year or dollar amount for escalation purposes (operating expenses, real estate taxes and management fee); 13) any other adjustments (including by way of indexes) to base rental; 14) credit standing of the tenant; 15) term or length of lease; 16) the time the particular rental rate under consideration was agreed upon and became or is to become effective; and 17) any other concession or inducement and/or relevant term or condition in making such fair market value rental rate determination. In each and every instance under the Lease in which Market Rate is to be determined, integral to such determination shall be all relevant economic factors as enumerated above (unless this Lease expressly provides otherwise), including, but not limited to, lease takeovers, abatements, leasehold improvements and other allowances. If there is a dispute between Landlord and Tenant relating to the determination of the Market Rate and the parties cannot in good faith resolve such issue within thirty (30) days,



then either Landlord or Tenant may at their sole discretion (i) terminate the negotiations or (ii) use reasonable efforts to agree within ten (10) days following the expiration of such thirty (30) day period upon the appointment of one (1) broker to resolve the matter. If an agreement on a single broker cannot be reached within the ten (10)-day period, Landlord and Tenant shall each appoint their own respective broker within ten (10) business days following the elapse of the ten (10)-day period and shall specify the name and address of their respective broker to the other party prior to the expiration of such ten (10)-business day period; provided, that if one party fails to specify the name and address of its selected broker within such ten (10)-business day period, the other party shall give the failing party written notice and if within five (5) days after such written notice the failing party still has not specified a broker, the broker selected by the other party shall act as the single broker as if both parties had agreed to the appointment of such broker as provided above. The selected brokers shall then meet within ten (10) days of the appointment of the last of the two, and if such brokers are unable to agree upon such matter within fifteen (15) days, they shall appoint a third broker within ten (10) business days following expiration of this period. If the two brokers are unable to agree upon a third broker within such ten (10) business day period, the third broker shall be appointed as soon as reasonably possible thereafter by the American Arbitration Association (or any successor organization, or if no successor organization shall then exist, by a court of competent jurisdiction residing in Harris County, Texas), subject to the qualification requirements set forth below. The term "broker" shall mean a real estate broker licensed in the State of Texas who has at least fifteen (15) years of experience with leasing of office buildings and locations in the area of Houston, Harris County, Texas located within a two (2) mile radius of the Project and have brokered and completed at least three (3) office leases in excess of 25,000 square feet in such area during the immediately preceding twelve (12) months. The cost and expense incurred by the brokers' review shall be borne equally by the parties.

Expansion Option space for all or a portion of floor four (4) of the office building of the Project shall be exercised by the Tenant within twelve (12) months from execution of the Lease Effective Date. In the event the Tenant exercises the Expansion Option, Tenant shall have the option to renew the Expansion Option space for a period of two (2) or five (5) years. Renewal term for the Expansion Option space if exercised, is at the sole discretion of the Tenant and shall be based on the dollars per square foot as described in Section 1.1(k).

In the event of such Expansion Option space and renewal thereof, if any, "Lease Term" as used in this Lease, shall include the Expansion Option and Renewal Term, and such renewal of this Lease shall be upon the same terms and conditions applicable during the original Lease Term, except that Rent for the Renewal Term shall be as established above.

Section 3.5 Except as expressly provided to the contrary in this Lease (including, without limitation, Article 4), Tenant shall not be required to pay for cost adjustments resulting from operating expense escalations during the Lease Term; provided, however, the parties acknowledge and agree that with respect to any Renewal Term for floors nine (9) and ten (10), Rent shall be adjusted to the Market Rate, which shall include adjustments to operating expenses as of the commencement of such Renewal Term. The

Operating Expenses of the Expansion Option and Renewal Term for the lease of the Floor 4 space under the Expansion Option, if exercised, shall be calculated in accordance with Section 3.4 and "Base Operating Expenses" shall be defined as the actual Operating Expenses incurred by Landlord for the calendar year of 2024 (subject to adjustment pursuant to Section 3.2(c)).

Section 3.6 Tenant may terminate this Lease at any time after three (3) years from commencement date of the Lease; however, Tenant shall provide Landlord with at least a six month written notice of termination and reimburse the Landlord the unamortized portion of the broker commission fees over the Lease term.

#### **ARTICLE 4.**

##### **Improvements, Maintenance and Repair of the Leased Premises**

Section 4.1 Landlord, at its sole cost and expense, shall build out the Leased Premises as listed in the Work Letter attached as **Exhibit "D-1"** to this Lease (the "Work Letter") and the Tenant Specifications (hereinafter defined in the Work Letter and attached as **Exhibit "D"** to this Lease), as listed below and as may additionally be agreed upon in writing by the Parties. Tenant shall not be entitled to make any changes to the Tenant Specifications set forth on **Exhibit "D"**. Landlord shall not be required to make any alterations or improvements to the Leased Premises, including data wiring and IT equipment, except as expressly set forth in this Lease and the exhibits hereto.

Tenant shall be provided 6.0 watts per usable square foot for high - and low - voltage requirements, to include "Building Standard" lighting and convenience outlets, but not including any electricity for any item that requires a voltage other than 120 volts, single phase. All Building Standard electrical power shall be supplied by Landlord.

The HVAC system shall have sufficient cooling and heating capacity to maintain an average inside air temperature of 72 degrees +/- 2% FDB and relative humidity at 50% +/-8% during summer and 72 degrees FDB during winter based on 99.6% ASHRAE design conditions. Without limiting the foregoing, if any of Tenant's electrical equipment, including without limitation, the computer server equipment and mail room equipment to be installed in the Leased Premises, requires conditioned air in excess of the standard amount for conventional office building operation in the City of Houston, then all reasonable costs and expenses incurred from time to time in connection with such excess air conditioning equipment, including, without limitation, all costs and expenses relating to the design, installation, operation, maintenance, repair and replacement thereof shall be the responsibility of Tenant. Landlord shall provide HVAC service at times outside of Hours of Operation upon Tenant's request with Tenant paying for such after-hours HVAC at Landlord's current after hours HVAC rates, which after hours HVAC rate may be

changed by Landlord from time to time during the Lease Term based on the increase in electrical costs in Landlord's electrical contract. If the Landlord increases the after-hours HVAC rate based on such contract, then Tenant shall have the right to review such electrical contract.

Section 4.2 In the event the Landlord has not substantially completed the build out of the Leased Premises by January 2, 2019 (or February 1, 2019 if extended as provided in Section 1.1(e)), Tenant may, upon thirty (30) day written notice, terminate the Lease without any further obligation to the Landlord. In the event the Landlord presents Tenant build-out plans or related documents for review and approval during the build-out phase, Tenant shall respond within three (3) business days; and any failure to timely respond will extend the above deadline by the number of days Tenant exceeds such three (3) business days. Moreover, such date shall be further extended by one (1) day for each day of Delay (as such term is defined in **Exhibit "D-1"** attached hereto).

Section 4.3

(a) Landlord shall provide Tenant up to three (3) unreserved parking spaces in the garage attached to the Project per one thousand square feet leased (3/1,000) at a rate of sixty-five dollars (\$65.00) per space per month exclusive of applicable taxes. Landlord shall abate unreserved garage parking rental for the first three (3) years of the Lease. Tenant may elect to convert up to ten percent (10%) of the above allocable ratio to reserved spaces during the term of the Lease at a rate of one hundred twenty dollars (\$120.00) per month per space. After the first 12 months of the Lease Term, Tenant shall have one time right of cancellation of the reserved spaces and the rental charge for such reserved spaces shall be terminated.

(b) Tenant shall notify Landlord no later than the last day of the twelve (12) month of the Lease of the number of parking spaces it desires whether reserved or unreserved. Landlord reserves the right, after thirty (30) days advance written notice to Tenant, to locate unreserved parking spaces in excess of two spaces per one thousand (2/1,000) square feet leased to a parking facility within two (2) blocks of the Project during the remainder of the Term or Tenant will at its cost, move 80 of the unreserved parking spaces to 700 Pierce with the remaining 40 unreserved parking spaces staying in the garage.

(c) Tenant may park up to thirty (30) vehicles needing overnight storage on the roof of the garage attached to the Project at no cost to the Tenant during the Lease term.

(d) All visitor surface parking serving all of the tenants of the Project and their invitees in front of the Project and all visitor parking on the first floor of the Project garage will be designated as one (1) hour parking. Landlord reserves the right to make changes to the number of visitor parking spaces as well as the parking charges to the visitors to use such spaces.

(e) Landlord shall restripe the surface parking lot at 700 Pierce.

Section 4.4 Landlord shall provide at no cost to Tenant, in a good and workmanlike manner and in accordance with all applicable law, a building card key access system for entry into the Project and Leased Premises. Landlord shall provide Tenant with 180 card keys at no cost to Tenant; additional card keys shall cost Tenant \$2.00 for each card key.

Section 4.5 Landlord shall provide base building carpet for the Leased Premises as set forth in the Work Letter.

Section 4.6 Subject to the terms of this Section 4.6, Landlord shall provide as a part of Operating Expenses all maintenance and make any necessary repairs and replacements to the foundation; the walls; plate glass windows, doors, door closure devices and other exterior openings; window and door frames; locks and hardware securing the Leased Premises; molding; exterior lighting fixtures; natural gas, water, sanitary sewer and electricity lines; the roof; heating and air conditioning equipment; and electrical, mechanical and plumbing equipment serving the Leased Premises. In addition, Landlord shall keep the sidewalks, parking areas and service areas adjacent to the Leased Premises in good and clean condition. In the event the Leased Premises shall be in need of repairs required to be made by the Landlord, Tenant shall give immediate written notice thereof to Landlord. Tenant shall be responsible for the cost to maintain, repair or replace any of the foregoing to the extent necessitated by the negligence or willful misconduct of Tenant, its agents, employees or contractors.

Section 4.7 On the Occupancy Date, Landlord shall deliver the Leased Premises to Tenant in a vacant condition, free of debris and furniture, and provide it in clean, good working order, with all pre-existing mechanical, electrical and plumbing systems in good working condition. Landlord shall have the Leased Premises in compliance with the Americans with Disabilities Act and the regulations thereunder and all other applicable regulatory codes applicable to the Project (collectively, the "Accommodation Laws") as enacted and interpreted as of the Occupancy Date, and any repairs, remodeling or retrofitting required for Landlord to be in compliance with the foregoing as of the Occupancy Date shall be performed by Landlord, at Landlord's sole cost and expense.

Section 4.8 By taking possession of the Leased Premises, Tenant is deemed to have accepted the Leased Premises and agreed that the Leased Premises is in good order and satisfactory condition. Following the Occupancy Date, (a) Tenant shall assume all responsibility for compliance with the Accommodation Laws (as enacted and interpreted after the Occupancy Date) relating to the interior of the building on the Leased Premises and the activities conducted by Tenant therein, and (b) Landlord shall retain all responsibility for compliance with the Accommodation Laws (as enacted and interpreted after the Occupancy Date) relating to the exterior of the building and the parking areas on the Leased Premises (excluding the Covered Parking, which shall be the responsibility of Tenant). In the event Tenant fails to comply with the requirements of this Section 4.8 within a reasonable time after written notice from Landlord, Landlord shall have the right to perform the same on Tenant's behalf and at Tenant's expense.

Section 4.9 At the expiration or termination of this Lease, Tenant shall surrender the Leased Premises in good condition, excluding reasonable wear and tear, Landlord's maintenance obligations and loss by fire or other casualty excepted, and shall surrender all keys for the Leased Premises to Landlord.

**ARTICLE 5.**  
**General Services**

Section 5.1 Except as expressly provided to the contrary in this Lease, Landlord agrees to provide and maintain, as a part of Operating Expenses, the following services:

- (a) Working and adequate central heating, ventilation and air conditioning during Tenant's hours of operation;
- (b) Cold water for drinking, lavatory and toilet purposes drawn through fixtures installed by Landlord and hot water for lavatory purposes;
- (c) Shades, blinds, or the like, as may be agreed upon by Landlord and Tenant;
- (d) Building standard LED lighting fixtures installed by Landlord and replacement of defective LED lamps in such fixtures as needed from time to time. Lighting for the parking areas directly west of the building of the Project shall be operated and maintained using lighting per City of Houston Lighting Code;
- (e) Janitorial services and supplies in and about the Leased Premises, once per day and five days per week; provided that Landlord shall have use of the mechanical rooms for storage of janitorial and maintenance supplies associated with the operation of the Project;
- (f) All areas in and about the Leased Premises, including, but not limited to, all restrooms and the public areas and elevator lobbies on all floors shall comply with the Accommodation Laws, subject to Section 4.7 of this Lease. The maintenance of the public areas will occur during all Hours of Operation, including, but not limited to, removal of all trash and maintain compliance with all applicable law;
- (g) Pest control services throughout the Leased Premises as needed by Tenant; and
- (h) Trash dumpsters and disposal service as needed by Tenant during all Hours of Operation for commercially reasonable volumes and types of trash produced by Tenant (and Tenant only) at the Leased Premises; provided, however, Tenant shall not use the dumpsters provided by Landlord hereunder for the disposal of any Hazardous Material (hereinafter defined).

- (i) Landlord shall provide on-site security guard and lobby receptionist with the following hours:

Security Guard: 5:00 pm – 7:00 am – seven days per week

Lobby Receptionist: 7:00 am – 5:00 pm Monday - Friday

For the purposes hereof, "Essential Services" shall mean 50% of HVAC, 50% of the electricity and 50% of the water and all elevators serving the Leased Premises. In the event of service interruption of Essential Services to the Leased Premises which such failure (i) is the result of conditions within Landlord's reasonable control and (ii) continues for more than four (4) consecutive business days after written notice to Landlord by Tenant of such interruption of Essential Services, Monthly Rent shall be abated for the period commencing on the sixth (6th) business day of interruption of such Essential Services and terminating on the day of restoration of the Essential Services. Failure to re-establish Essential Services for more than thirty (30) consecutive days shall constitute default and Tenant, at its sole discretion, may terminate the Lease.

Section 5.2 Landlord shall pay, before delinquency, all taxes and assessments of every nature which are levied upon or assessed against the Project by any political subdivision and for whatever purpose.

Section 5.3 Tenant shall be responsible for all charges for telephone, internet, and other communication services furnished to the Leased Premises. Upon the termination of this Lease, Tenant shall have the right to remove any telephone equipment owned by Tenant. Tenant shall promptly repair any damage to the Leased Premises caused by such removal.

#### **ARTICLE 6.** **Landlord's Right of Access**

Upon twenty-four (24) hour advance written notice to Tenant or without notice in the event of an emergency, Landlord shall have the right to enter upon the Leased Premises for the purpose of inspecting or making repairs, alterations or additions to the Leased Premises, or showing the Leased Premises to prospective lenders, purchasers or, during the last twelve (12) months of the Lease Term, to prospective tenants; provided, however, Tenant shall have the right to select another time or date within twenty-four (24) hours of Landlord's desired time and date for Landlord to enter the Leased Premises in a non-emergency situation. Non-emergency entries upon the Leased Premises by Landlord shall be during normal business hours and coordinated with Tenant so as to minimize the interference with Tenant's use of the Leased Premises; provided, however, Landlord may enter the Leased Premises without advance notice for the purpose of (a) performing routine janitorial and other services that Landlord is required to perform under this Lease, and (b) monitoring Tenant's electrical usage within the Leased Premises in accordance with Section 4.1 of the Lease. Notwithstanding the foregoing, Landlord and Tenant acknowledge and agree that certain areas within the Leased Premises may contain sensitive or confidential information of Tenant and that Landlord will be restricted

from accessing such areas unless accompanied by Tenant. Tenant agrees to notify Landlord in writing of any such restricted areas as soon as reasonably practical after the Occupancy Date.

**ARTICLE 7.**  
**Alterations and Fixtures**

Tenant shall not make any alterations, additions or improvements, including but not limited to structural work, to the Leased Premises without the prior written consent of Landlord, which consent will not unreasonably be delayed or denied (with respect to non-structural alterations only); however, Tenant shall not be required to obtain any consent whatsoever from Landlord for any alterations, additions or improvements which only involve (i) the installation and removal of unattached, movable furniture and trade fixtures which may be installed without drilling, cutting or otherwise defacing the Leased Premises, or (ii) any interior lighting, window or door lettering, placards, decorations or paintings. All alterations, additions, improvements and unattached, movable furniture and trade fixtures made or installed by Tenant upon the Leased Premises shall remain the property of Tenant and may be removed by Tenant at any time, including upon the expiration or termination of this Lease; provided, however, Tenant shall promptly repair any damage to the Leased Premises caused by such removal. Any linoleum, carpeting or other floor covering which may be cemented or otherwise affixed to the floor of the Leased Premises is a permanent fixture and shall become the property of Landlord.

**ARTICLE 8.**  
**Mutual Release**

**Section 8.1 LANDLORD SHALL RELEASE TENANT FROM AND HEREBY WAIVES WITH RESPECT TO TENANT ANY AND ALL CLAIMS OR LIABILITY FOR ANY INJURY OR DAMAGE TO ANY PERSON OR PROPERTY IN, ON OR ABOUT THE PROJECT OR ANY PART THEREOF, TO THE EXTENT SUCH INJURY OR DAMAGE SHALL BE CAUSED BY THE ACT, NEGLIGENCE, FAULT OF, OR OMISSION BY LANDLORD, OR ITS AGENTS, SERVANTS OR EMPLOYEES, INCLUDING BUT NOT LIMITED TO CLAIMS UNDER THE ACCOMMODATION LAWS (BUT ONLY WITH RESPECT TO CLAIMS RELATING TO VIOLATIONS ARISING AS OF THE OCCUPANCY DATE).**

**Section 8.2 TENANT SHALL RELEASE LANDLORD FROM AND HEREBY WAIVES WITH RESPECT TO LANDLORD ANY AND ALL CLAIMS OR LIABILITY FOR ANY INJURY OR DAMAGE TO ANY PERSON OR PROPERTY IN, ON OR ABOUT THE PROJECT OR ANY PART THEREOF, TO THE EXTENT SUCH INJURY OR DAMAGE SHALL BE CAUSED BY THE ACT, NEGLIGENCE, FAULT OF, OR OMISSION BY TENANT, OR ITS AGENTS, SERVANTS OR EMPLOYEES, INCLUDING BUT NOT LIMITED TO CLAIMS UNDER THE ACCOMMODATION LAWS (BUT ONLY WITH RESPECT TO CLAIMS RELATING TO VIOLATIONS ARISING AFTER THE OCCUPANCY DATE).**

Section 8.3 UPON THE FILING BY ANYONE OF ANY TYPE OF CLAIM, CAUSE OF ACTION OR LAWSUIT AGAINST LANDLORD OR TENANT FOR ANY TYPE OF DAMAGES ARISING OUT OF INCIDENTS FOR WHICH THE OTHER PARTY MAY BE LIABLE, THE PARTY BEING SUBJECT TO SUCH CLAIM, CAUSE OF ACTION OR LAWSUIT SHALL NOTIFY THE OTHER PARTY OF THE SAME.

**ARTICLE 9**  
**Casualty and Liability Insurance**

Section 9.1 As a part of Operating Expenses, Landlord shall obtain (or cause its applicable vendor or other service professional to obtain) and maintain in full force and effect throughout the Lease Term and any extensions or renewals thereto the following insurance:

(a) Standard Fire and Extended Coverage Insurance insuring the Project and all building-standard improvements or additions to the Leased Premises for the full replacement cost thereof with reasonable deductibles (excepting tenant's personal property and trade fixtures);

(b) Worker's Compensation Insurance in accordance with statutory requirements; and

(c) Commercial General Liability Insurance, including blanket contractual liability, products and completed operations, personal injury, bodily injury, broad form property damage, operations hazard, explosion, collapse and underground hazards for not less than \$1,000,000 combined single limit arising out of any one occurrence and a general 12-month aggregate limit of at least \$2,000,000.

Section 9.2 All insurance policies shall be issued by a company or companies with a valid certificate of authority to do business in the State of Texas issued by the Texas State Board of Insurance and rated "A" or better in the most current edition of Best's Insurance Reports, and all commercial general liability insurance policies shall also name Tenant as an additional insured. Landlord shall deliver to Tenant copies of all insurance certificates and policies required to be carried by Landlord under this Lease, with evidence of payment of premiums for such policies, within thirty (30) days after execution of this Lease. With respect to renewals of such policies, Landlord shall deliver to Tenant an insurance certificate not later than thirty (30) days prior to the end of the expiring term of coverage and deliver to Tenant a copy of such insurance policies promptly upon their receipt by Landlord. Upon Tenant's request and to the extent reasonably available, Landlord shall deliver to Tenant certified copies of such policies. All such policies and certificates shall contain an agreement that the insurer shall notify Tenant in writing not less than thirty (30) days before any material change, reduction in coverage, or cancellation of any policy (or not less than ten (10) days with respect to the non-payment of premiums). All such insurance policies and certificates shall also include a clause or endorsement denying Landlord's insurer any right of subrogation against Tenant (the "Subrogation Waiver Endorsement"). LANDLORD HEREBY WAIVES ANY RIGHT OF RECOVERY, CLAIM, CAUSE OF ACTION OR ACTION AGAINST TENANT



FOR INJURY OR LOSS (INCLUDING, WITHOUT LIMITATION, INJURY OR LOSS CAUSED BY THE SOLE NEGLIGENCE OF TENANT) BY REASON OF ANY CAUSE REQUIRED TO BE INSURED BY LANDLORD IN THIS LEASE, WHICH WAIVER SHALL BE EFFECTIVE FOR PURPOSES OF THE SUBROGATION WAIVER ENDORSEMENT.

Section 9.3 As a political subdivision of the State of Texas and governmental unit, Tenant is self-insured under the Texas Tort Claims Act (Chapter 101, *et seq.*, Tex. Civ. Pac. & Rem. Code Ann.) and its statutory liability is limited to a maximum amount of \$100,000 per person and \$300,000 for each single occurrence for bodily injury or death and \$100,000 for each single occurrence for injury to or destruction of property. Under its status as a political subdivision, Tenant does not provide or purchase insurance for Commercial General Liability, Blanket Contractual Liability, Broad Form Property Damage, Personal and Advertising Injury, Completed Operations/Products Liability, Medical Expenses, and Interest of Employees as additional insureds. Additionally, as a political subdivision, Tenant provides Workers' Compensation benefits to Tenant's employees involved in the performance of this Agreement under a self-insurance plan pursuant to Tex. Labor Code Ann § 504.011, as amended. TENANT HEREBY WAIVES ON ITS OWN BEHALF AND ON BEHALF OF ANY PARTY CLAIMING BY, THROUGH OR UNDER TENANT, ANY RIGHT OF RECOVERY, CLAIM, OR CAUSE OF ACTION AGAINST LANDLORD FOR INJURY OR LOSS (INCLUDING, WITHOUT LIMITATION, INJURY OR LOSS CAUSED BY THE SOLE NEGLIGENCE OF LANDLORD) TO THE EXTENT THAT SUCH INJURY OR LOSS WOULD HAVE BEEN COVERED UNDER STANDARD INSURANCE POLICIES COMMONLY HELD BY LESSEES IN SIMILAR COMMERCIAL OFFICE BUILDINGS IN HOUSTON, HARRIS COUNTY, TEXAS.

## **ARTICLE 10**

### **Damage by Casualty**

Section 10.1 . In the event the Leased Premises are wholly or partially damaged or destroyed by a fire, storm, tornado, or other casualty, then, unless this Lease is terminated as hereinafter provided, Landlord shall perform Landlord's Restoration Work (as hereinafter defined) with reasonable dispatch and continuity. "Landlord's Restoration Work" shall mean all of the work necessary to repair and restore the Leased Premises to substantially the same condition the Leased Premises was in immediately prior to such casualty, except for Tenant's trade fixtures and personal property, the restoration of which shall be the sole responsibility of Tenant. Tenant shall give prompt written notice to Landlord of any such damage, and Landlord shall, within thirty (30) days following the receipt of such notice, furnish to Tenant an estimate (the "Estimate") prepared and certified by an independent architect or contractor selected by Landlord and reasonably acceptable to Tenant, of the date (the "Restoration Date") by which Landlord's Restoration Work is reasonably scheduled to be completed. If the Restoration Date is a date later than one hundred eighty (180) days after the date Tenant receives the Estimate, then Tenant may, at its option, terminate this Lease by giving written notice to Landlord within ten (10) days after Tenant's receipt of the Estimate. In any case where the Estimate does not give rise to Tenant's termination right set forth above (as well as any case where Tenant does not elect to exercise its termination right set forth above), Tenant shall have the right to terminate this Lease if for any reason Landlord's Restoration Work is not

completed within thirty (30) days after the Restoration Date. Tenant may exercise the termination right described in the preceding sentence by delivering written notice thereof to Landlord at any time following the Restoration Date and prior to the date Landlord completes Landlord's Restoration Work. If Tenant terminates this Lease as provided in this Section 10.1, then such termination shall be effective on the date specified in Tenant's notice of termination but no later than one hundred eighty (180) days after the date of such notice as if such date were the date fixed for the expiration of the Term. Tenant shall have the option to extend the Lease Term for a period equal to the number of days from the occurrence of the casualty until the Restoration Date, with such extension to be at the same rental rate that was in effect immediately prior to the casualty. Each party shall give the other party immediate written notice of any damage caused to the Leased Premises by fire or other casualty. If the Leased Premises are partially damaged or destroyed or rendered unfit for the operation of Tenant's business, then the Rent shall be abated in proportion to the area of the Leased Premises that has been rendered unfit for the operation of Tenant's business or inaccessible for the period from the date of such damage or destruction until the Landlord's Restoration Work is Substantially Completed (as such term is defined in **Exhibit "D-1"** attached hereto). If the Leased Premises is totally destroyed or rendered unfit for the operation of Tenant's business, then the Rent shall abate completely as of the date of the damage or destruction and until the Landlord's Restoration Work is Substantially Completed (as such term is defined in **Exhibit "D-1"** attached hereto).

#### **ARTICLE 11.** **Eminent Domain**

Section 11.1 If any of the floor area of the Leased Premises should be taken for any public or quasi-public use under any governmental law, ordinance or regulation or by right of eminent domain or by private purchase in lieu thereof, which taking materially interferes with Tenant's use and occupancy of the Leased Premises, either party shall have the option to terminate this Lease within thirty (30) days after the above determination. If neither party terminates this Lease within such time period, Landlord shall make all necessary repairs or alterations to make the Leased Premises an architectural whole.

Section 11.2 All compensation awarded for any taking (or the proceeds of a private sale in lieu thereof) of the Project or the Leased Premises shall be the property of Landlord; and Tenant shall not be entitled to any part of the compensation paid for the taking of Tenant's leasehold estate; provided, however, Tenant shall be entitled to seek compensation for any of Tenant's personal property taken by the condemning authority, which would remain the property of Tenant if this Lease expired in accordance with its terms, provided such award in no way diminishes Landlord's award for the taking of the Project, the Leased Premises or any leasehold estate therein.

#### **ARTICLE 12** **Assignment and Subletting**

Section 12.1 Tenant shall not have the right to assign, sublet, transfer or encumber this Lease, or any interest therein, without the prior written consent of Landlord which consent shall not be unreasonably withheld. If Tenant's assignee, sublessee, or transferee will not have similar general office and visitor use as Tenant, then Landlord's denial of consent to such assignment, sublease, or transfer would not be considered unreasonably withheld.

Section 12.2 In the event of the transfer or assignment by Landlord of its interest in any portion of the Leased Premises or this Lease, Landlord shall be released from any obligations hereunder pertaining to such portion of the Leased Premises or this Lease arising after the date of transfer or assignment; however, Landlord shall not be released and will continue to be liable for any obligations arising prior to such transfer or assignment.

**ARTICLE 13.**  
**Default by Tenant and Remedies**

Section 13.1 The occurrence of any of the following events shall constitute an "Event of Default" by Tenant under this Lease:

- (a) Tenant shall fail to pay any Rent, or any other expense demanded by Landlord as herein provided, and such failure shall continue for a period of ten (10) days after written notice thereof to Tenant by Landlord (provided that Landlord shall not be required to provide such notice more than two (2) times during any calendar year, after which time an Event of Default shall occur immediately upon Tenant's failure to pay Rent and other sums owed when due under the Lease).
- (b) Tenant shall fail to comply with any term, provision or covenant of this Lease, other than the payment of the Rent or expenses demanded by Landlord, and such failure shall continue for a period of thirty (30) days after written notice thereof to Tenant by Landlord.

Section 13.2 Upon the occurrence of an Event of Default under Section 13.1(a), Landlord shall have the option to terminate this Lease, or to pursue any other remedies at law or in equity. Upon the occurrence of an Event of Default under Section 13.1(b), Landlord shall have the option, provided Tenant fails to cure such default after Landlord has given Tenant an additional thirty (30) days prior written notice specifying such default with particularity, to terminate this Lease, or to pursue any other remedies at law or in equity.

**ARTICLE 14**  
**Default by Landlord and Remedies**

Section 14.1 If Landlord defaults in the performance of any covenants or agreements contained within this Lease and fails to cure such default within thirty (30) days after written notice thereof is given by Tenant describing such default with particularity (provided, however, that if such default cannot reasonably be cured within

said thirty (30) day period said period shall be extended so long as Landlord shall diligently prosecute such cure to completion) then Tenant may, at its option, terminate this Lease or pursue any other remedies available to Tenant at law or in equity. Notwithstanding anything to the contrary contained in this Lease, in the event of a default by Landlord as described above, Tenant shall be entitled to cure such default on behalf of and at the expense of Landlord (hereinafter referred to as "Tenant's Right of Self-Help"), subject to the terms and conditions of this Section 14.1. Tenant shall not be entitled to exercise Tenant's Right of Self-Help unless and until (a) Tenant has provided Landlord with an additional written notice of Landlord's default under this Lease and thirty (30) days thereafter to cure such default and (b) Landlord fails to cure such default within such additional time period. Tenant's Right of Self-Help shall permit Tenant to perform all reasonable and necessary work and make all necessary payments to protect Tenant's continued use and occupancy of the Leased Premises. Landlord shall pay Tenant on demand the reasonable, out-of-pocket costs incurred and any amounts so paid by Tenant on behalf of Landlord arising out of Tenant's exercise of Tenant's Right of Self-Help, together with all interest accrued thereon at a rate of one percent (1%) per month, or if such rate is above the maximum legal rate then at the maximum legal rate, until Tenant has been completely reimbursed.

#### **ARTICLE 15.** **Subordination**

Tenant accepts this Lease subject and subordinate to any mortgage, deed of trust or other lien presently existing or hereafter created upon the Project, and to any renewals and extensions thereof. Landlord is hereby irrevocably vested with full power and authority to subordinate this Lease to any mortgage, deed of trust or other lien hereafter placed upon the Project, and Tenant agrees to execute such further instruments subordinating this Lease as Landlord may request. Tenant's subordination shall be expressly conditioned upon Landlord securing a non-disturbance agreement from any lender, which assures Tenant that in the event of foreclosure, or in the event title to the Project is transferred in lieu of such foreclosure, or in the event any lender directly or indirectly becomes the new landlord of the Leased Premises, that the terms of this Lease will not be terminated, disturbed, or adversely affected, so long as Tenant is not in default at such time. Landlord agrees that, within thirty (30) days from the date of execution of this Lease, it will provide Tenant with commercially reasonable non-disturbance agreements in favor of Tenant from any ground lessors, mortgage holders or lien holders then in existence or, if none are in existence, Landlord shall acknowledge that there are no ground lessors, mortgage holders or lien holders. Said non-disturbance agreements shall be recorded, at Tenant's election and at Tenant's sole cost and expense, in the Real Property Records of Harris County, Texas. In the event Landlord fails to provide such non-disturbance agreements within the time frame set forth herein, Tenant shall have the right to terminate this Lease and Landlord shall reimburse Tenant for all of Tenant's out-of-pocket costs incurred in connection with this Lease; provided, however, such right shall be waived unless exercised by Tenant within sixty (60) days after Landlord fails to provide the non-disturbance agreement within the time frame set forth herein.

#### **ARTICLE 16.**

## Environmental Restrictions

Section 16.1 Neither Landlord nor Tenant shall transport, use, store, maintain, generate, manufacture, handle, dispose, release or discharge any "Hazardous Material" (hereinafter defined) upon or about the Project, nor permit their employees, agents, and contractors to engage in such activities upon or about the Project. However, the foregoing provisions shall not prohibit the transportation to and from, and use, storage, maintenance and handling within the Project of substances customarily used in owning, managing, repairing, leasing, or operating real estate similar to the Project; provided (i) such substances shall be used and maintained only in such quantities as are reasonably necessary and in accordance with applicable law and the manufacturers' instructions therefor and (ii) such substances may be disposed of, released or discharged at the Project if permitted by and in compliance with applicable laws, and shall be transported to and from the Project in compliance with all applicable laws.

Section 16.2 Each party shall promptly notify the other party upon the notifying party becoming aware of: (i) any enforcement, cleanup, or other regulatory action taken or threatened against either party by any governmental or regulatory authority with respect to the presence of any Hazardous Material on the Project, (ii) any demands or claims made or threatened by any party against Landlord, Tenant relating to any loss or injury resulting from any Hazardous Material, (iii) any unlawful release, discharge or nonroutine, improper or unlawful disposal or transportation of any Hazardous Material on or from the Project, and (iv) any matters where the party is required by law to give a notice to any governmental or regulatory authority respecting any Hazardous Materials in Building. At such times as Tenant may reasonably request, Landlord shall provide Tenant with a written list identifying any Hazardous Material then actually known to Landlord to be then used, stored, or maintained upon the Project, a copy of any material safety data sheet ("MSDS") issued by the manufacturer therefore, written information concerning the removal, transportation and disposal of the same, and such other information as the requesting party may reasonably require or as may be required by laws. At such times as Landlord may reasonably request, Tenant shall provide Landlord with an MSDS issued by the manufacturer therefore, written information concerning the removal, transportation and disposal of the same, and such other information as the requesting party may reasonably require or as may be required by laws. The term "Hazardous Material" shall mean any chemical, substance, material or waste or component thereof which is now or hereafter listed, defined or regulated as a hazardous or toxic chemical, substance, material or waste or component thereof by any federal, state or local governing or regulatory body having jurisdiction or under any applicable environmental laws, or which would trigger any employee or community "right-to-know" requirements adopted by any such body, or for which any such body has adopted any requirements for the preparation or distribution of an MSDS.

Section 16.3 If any Hazardous Material is released, discharged or disposed of by Landlord or Tenant or their respective employees, agents or contractors, on or about the Project in violation of the foregoing provisions, the releasing, discharging or disposing party shall immediately, properly and in compliance with all applicable laws and ordinances, clean up and remove the Hazardous Material from the Project and any other

affected property, at such party's sole cost and expense. Such clean up and removal work shall include, without limitation, any testing, investigation and/or preparation and implementation of any remedial action plan required by any governmental body having jurisdiction. If the releasing, discharging or disposing party shall fail to comply with the provisions of this Section within five (5) days after written notice by the other party, or such shorter time as may be required by law, the other party may (but shall not be obligated to) arrange for such compliance directly through contractors or other parties selected by the other party, at the releasing, discharging or disposing party's expense.

Section 16.4 Landlord represents and warrants to Tenant that, to Landlord's knowledge, (i) the Leased Premises have been tested for airborne fibers (including, but not limited to, asbestos fibers) using the Phase Contrast Microscopy, NIOSH 7400 method, and the amount of airborne fibers on the Leased Premises shown by such testing does not exceed 0.01 fibers per cubic centimeter, and (ii) the air conditioning ducts on the Leased Premises are self-contained from other parts of the Project in a manner which would substantially prevent asbestos containing materials from being transmitted to the Leased Premises through the air conditioning ducts. Landlord has provided or will provide within ten (10) days after the Lease Effective Date copies of all reports in Landlord's possession relating to the tests described above.

Section 16.5 Landlord gives Tenant the right, upon prior written notice to Landlord, to test for airborne fibers, at Tenant's sole cost and expense, during normal business hours within the period of time beginning on the Lease Effective Date and ending thirty (30) days after the Occupancy Date, and in which event Tenant shall promptly provide Landlord with any "Test Result Notice". Unless required otherwise by any federal, state or local law, rule or ordinance governing asbestos testing in Houston, Harris County, Texas (in which case Landlord covenants to comply with such application requirements), such testing shall be performed using Phase Contract Microscopy. If a Test Result Notice reveals that the airborne fiber level in any portion of the Leased Premises exceeds the "Acceptable Level" (defined as the lesser of (i) the lawful legal limit applicable to real estate in Houston, Harris County, Texas, or (ii) 0.01 fibers per cubic centimeter), Landlord shall have the option, for a period of thirty (30) days ("Retest Period") following such Test Result Notice, to conduct, as a part of Operating Expenses, additional testing to verify whether the asbestos fiber level in the Leased Premises exceeds the Acceptable Level. If, upon the expiration of the Retest Period, Landlord has elected not to conduct such additional testing or if Landlord has conducted such additional testing and such additional testing verifies that the asbestos fiber level in the Leased Premises exceeds the Acceptable Level, then Tenant shall have the option to either (a) continue to remain in the Leased Premises with all lease terms and conditions remaining unchanged or (b) terminate this Lease by giving written notice to Landlord (provided that such termination notice must be supplied within thirty (30) days after the expiration of the Retest Period or such right will be deemed waived by Tenant). Rent shall abate during the Retest Period (and any thirty (30) day period thereafter that Tenant is entitled to terminate this Lease), but only to the extent that Tenant does not occupy the Leased Premises during such periods.

If a Test Result Notice reveals that the airborne fiber level in any portion of the Leased Premises exceeds the "Acceptable Level" (defined as the lesser of (i) the lawful legal limit applicable to real estate in Houston, Harris County, Texas, or (ii) 0.01 fibers per cubic centimeter), then Tenant shall have the option, exercisable only for a period of thirty (30) days after Landlord's receipt of the Test Result Notice, to terminate this Lease by giving written notice to Landlord.

**ARTICLE 17.**  
**Notices**

Wherever any notice is required or permitted hereunder such notice shall be in writing. Any notice or document required or permitted to be delivered hereunder shall be deemed to be delivered when deposited in the United States mail, postage prepaid, Certified or Registered Mail, Return Receipt Requested, addressed to the parties hereto at their respective addresses set forth in the preamble paragraph of this Lease or such other address as may be specified by written notice.

**ARTICLE 18.**  
**Holding Over by Tenant**

In the event Tenant remains in the Leased Premises after the end of the Lease Term, Tenant shall become a month-to-month Tenant and pay Landlord a monthly rent equal to the amount paid by Tenant in the last month of the Lease Term for up to three (3) months as long as Tenant starts its relocation process more than six (6) months prior to lease expiration and sends Landlord notice of relocation efforts. Holdover payments will be paid in full month increments. After the three (3) month period the rent shall increase to 125% of the then current rent on a per diem basis.

**ARTICLE 19.**  
**Signage**

Landlord shall provide and keep in good repair exterior monument signage as part of Operating Expenses. Tenant's sign on Landlord's existing monument sign located on Milam Street shall be located on the middle top panel of such monument sign, and Tenant's sign on Landlord's existing monument sign located on Travis Street shall be located on the bottom left panel of such monument sign. The letters and wording on such signs shall be as mutually agreed to by Landlord and Tenant. All lettering will be provided by Landlord at no expense to the Tenant. Additionally, Landlord shall list Tenant in the Project's directory located in the main lobby of the Project. Landlord shall, at its expense, repair, paint and/or replace the surface to which its signage is attached upon vacation, desertion or abandonment of the Leased Premises by Tenant or removal or alteration of such signage.

**ARTICLE 20.**  
**Brokerage**

Landlord will pay in full a brokerage commission to Tenant's designated broker Cushman & Wakefield of Texas, Inc. and Landlord's designated broker Transwestern, under a separate commission agreement.

**ARTICLE 21.**  
**Estoppel Certificate**

Tenant shall from time to time, upon written request by Landlord or a lender, deliver to Landlord or a lender, within thirty (30) days after receipt of such request, a statement in writing certifying: (i) that this Lease is unmodified and in full force and effect (or if there have been modifications, identifying such modifications and certifying that the Lease, as modified, is in full force and effect); (ii) the dates to which Rent has been paid; (iii) that Landlord is not in default under any provision of this Lease (or if Landlord is in default, specifying each such default); (iv) the address to which notices to Tenant shall be sent, and (v) such other matters as may be reasonably requested by Landlord; it being understood that any such statement so delivered may be relied upon in connection with any lease, mortgage or transfer.

Tenant's failure to deliver such statement within such time shall be conclusive upon Tenant that: (i) this Lease is in full force and effect and not modified except as Landlord may represent; (ii) not more than one month's Rent has been paid in advance; (iii) there are no defaults by Landlord; and (iv) notices to Tenant shall be sent to Tenant's address as set forth in the preamble of this Lease. Notwithstanding the presumptions of this Article, Tenant shall not be relieved of its obligation to deliver said statement.

**ARTICLE 22.**  
**Force Majeure**

Landlord shall be excused for the period of any delay in the performance of any obligation hereunder when prevented from so doing by a cause or causes beyond its control, including all labor disputes, civil commotion, war, war-like operations, invasion, rebellion, hostilities, military or usurped power, sabotage, governmental regulations or controls, inability to obtain or delays in obtaining any governmental approvals or permits, fire or other casualty, inability to obtain or delay in obtaining any material, services or financing, or through acts of God. Tenant shall similarly be excused for delay in the performance of any obligation hereunder; provided:

- (a) nothing contained in this Article or elsewhere in this Lease shall be deemed to excuse or permit any delay in the payment of the Rent, or any delay in the cure of any default which may be cured by the payment of money;
- (b) no reliance by Tenant upon this Article shall limit or restrict in any way Landlord's right of self-help as provided in this Lease; and
- (c) Tenant shall not be entitled to rely upon this Article unless it shall first have given Landlord notice of the existence of any force majeure preventing the



performance of an obligation of Tenant within five days after the commencement of the force majeure.

**ARTICLE 23.**  
**Miscellaneous**

Section 23.1 Nothing contained herein shall be deemed or construed by the parties hereto, nor by any third party, as creating the relationship of principal and agent or of partnership or of joint venture between Landlord and Tenant, it being understood and agreed that neither the method of computation of rental, nor any other provisions contained herein, nor any acts of Landlord and Tenant, shall be deemed to create any relationship between Landlord and Tenant other than the relationship of landlord and tenant. Whenever herein the singular number is used, the same shall include the plural, and words of any gender shall include each other gender.

Section 23.2 In the event Landlord or Tenant will be interested in pursuing a buyout of the Leased Premises, the parties shall, in good faith, enter into such negotiation during the Initial Lease Term.

Section 23.3 The captions used herein are for convenience only and do not limit or amplify the provisions hereof.

Section 23.4 One or more waivers of any covenant, term or condition of this Lease by either party shall not be construed as a waiver of a subsequent breach of the same covenant, term or condition. The consent or approval by either party shall not be construed as a waiver of a subsequent breach of the same covenant, term or condition. The consent or approval by either party to or of any act by the other party requiring such consent or approval shall not be deemed to waive or render unnecessary consent to or approval of any subsequent similar act.

Section 23.5 Landlord covenants and agrees that, if Tenant shall perform all of the covenants and agreements herein required to be performed by Tenant, Tenant shall, subject to the terms of this Lease, have the peaceable and quiet enjoyment and possession of the Leased Premises.

Section 23.6 This Lease contains the entire agreement between the parties, and no agreement shall be effective to change, modify or terminate this Lease in whole or in part unless such agreement is in writing and duly signed by the party against whom enforcement of such change, modification or termination is sought. This Lease supersedes all prior proposals.

Section 23.7 The laws of the State of Texas shall govern the interpretation, validity, performance and enforcement of this Lease. Any action brought to enforce or interpret this Lease shall be brought in the court of appropriate jurisdiction in Houston, Harris County, Texas. Should any provision of this Lease require judicial interpretation, Landlord and Tenant hereby agree and stipulate that the court interpreting or considering

the same shall not apply the presumption that the terms hereof shall be more strictly construed against a party by reason of any rule or conclusion that a document should be construed more strictly against the party who prepared the same, it being agreed that all parties hereto have participated in the preparation of this Lease and that each party had full opportunity to consult legal counsel of its choice before the execution of this Lease.

Section 23.8 Each and every agreement contained in this Lease is, and shall be construed as, a separate and independent agreement. If any provision of this Lease should be held to be invalid or unenforceable, the validity and enforceability of the remaining provisions of this Lease shall not be affected thereby.

Section 23.9 Notwithstanding anything to the contrary in this Lease, all remedies of either party are cumulative and the election of a remedy by a party shall not foreclose such party from pursuing any other equitable or legal remedy.

Section 23.10 The terms, provisions and covenants contained in this Lease shall inure to the benefit of and be binding upon the parties hereto and their successors in interest.

Section 23.11 The Parties have executed this Agreement in multiple copies, each of which is an original. Each person signing this Agreement represents and warrants that he or she is duly authorized and has legal capacity to execute and deliver this Agreement. Each Party represents and warrants to the other that the execution and delivery of this Agreement and the performance of such Party's obligations hereunder have been duly authorized and that the Agreement is a valid and legal agreement binding on such Party and enforceable in accordance with its terms.

Section 23.12 Tenant hereby grants the Director of Tenant's General Services Department or his or her designee the right to enforce all legal rights and obligations under this Lease without further authorization from other City officials. Landlord covenants to provide to the City Attorney all documents and records that the City Attorney deems necessary to assist in determining Tenant's compliance with this Lease, with the exception of those documents made confidential by federal or State law or regulation.

Section 23.13 TIME IS OF THE ESSENCE IN THIS LEASE.

Section 23.14 Tenant shall, within 10 business days of Landlord's notification of Substantial Completion, shall pay the Landlord two million six hundred thirty thousand seven hundred sixty and 00/100 dollars (\$2,630,760.00) for the build out of the Leased Premises upon Substantial Completion of the Leased Premises by a wire transfer. Landlord shall provide Tenant with wiring instructions.

Upon payment of the two million six hundred thirty thousand seven hundred sixty and 00/100 dollars (\$2,630,760.00) to the Landlord, the monthly rent shall be decreased by twenty-one thousand nine hundred twenty-three and 00/100 (\$21,923.00) for the term of the Lease.

Section 23.15 Landlord understands that the Tenant may be required to appropriate additional funds for all or portion of the Base Operating Expenses during the Lease term and agrees that:

- (1) Tenant's duty to pay money to Landlord for any purpose under this Lease is limited in its entirety by the provisions of this Section.
- (2) In order to comply with Article II, Sections 19 and 19a of the City's Charter and Article XI, Section 5 of the Texas Constitution, the City has appropriated and allocated the sum of two million six hundred thirty thousand seven hundred sixty and 00/100 dollars (\$2,630,760.00) for Fiscal year 2018 and will appropriate and allocate the sum of one hundred four hundred eighty and 40/100 dollars (\$ 100,480.40) in Fiscal Year 2019 to pay money due under this Lease (the "Original Allocation"). The executive and legislative officers of the City, in their discretion, may allocate supplemental funds for this Lease, but they are not obligated to do so. Therefore, the parties have agreed to the following procedures and remedies:
- (3) The City makes a Supplemental Allocation by issuing to Landlord a Service Release Order, or similar form approved by the City Controller, containing the language set out below. When necessary, the Supplemental Allocation shall be approved by motion or ordinance of City Council.

#### **NOTICE OF SUPPLEMENTAL ALLOCATION OF FUNDS**

By the signature below, the City Controller certifies that, upon the request of the responsible director, the supplemental sum set out below has been allocated for the purposes of the Lease out of funds appropriated for this purpose by the City Council of the City of Houston. This supplemental allocation has been charged to such appropriation.

\$ \_\_\_\_\_

The Original Allocation plus all supplemental allocations are the Allocated Funds. The City shall never be obligated to pay any money under this Agreement in excess of the Allocated Funds. Landlord must assure itself that sufficient allocations have been made to pay for services it provides. If Allocated Funds are exhausted, Landlord's only remedy is suspension or termination of this Lease and it has no other remedy in law or in equity against the City and no right to damages of

any kind, except for recoupment of any unpaid Rent due and owing at the time of the suspension or termination of this Lease.

Tenant shall provide Landlord a copy of the City Ordinance approving this Lease.

Section 23.16 This Lease is subject to all terms and provisions of the Charter and Code of Ordinances of the City of Houston, Texas, and is subject to approval by the City Council of the City of Houston, Texas, and the signature of the Mayor and the counter-signature of the City Controller of the City of Houston, Texas to this Lease, and upon such approval and signatures, Tenant represents and warrants that all consents or approvals required for the execution, delivery and performance of this Lease have been obtained and that Tenant has the right and authority to enter into and perform its covenants and agreements contained in this Lease.

***[Signature pages follow]***

EXECUTED in multiple counterparts, dated as of the date of countersignature by the City Controller, and to be effective upon the Lease Effective Date.

"LANDLORD"

MIDTOWN CENTRAL SQUARE,  
LLC., a Texas limited liability  
company

By: Keeley Megarity

Name: Keeley Megarity

Title: Managing Member

Tax ID No. 46-2092060

***[Execution page for Tenant on following page]***

"TENANT"

CITY OF HOUSTON, TEXAS

ATTEST:



Anna Russell  
City Secretary

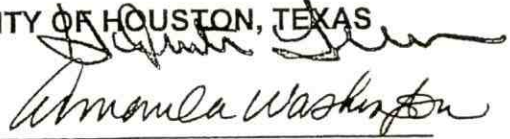

Sylvester Turner  
Mayor

APPROVED AND RECOMMENDED:

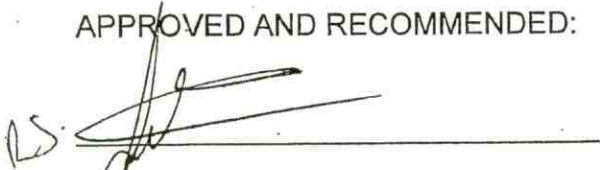
LS 

Richard A. Vella, Assistant Director  
of Real Estate, Design & Construction,  
General Services Department

COUNTERSIGNED:

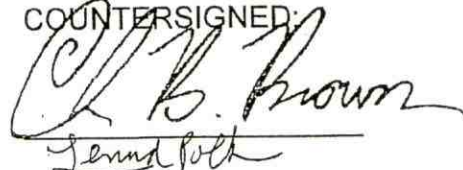

Chris B. Brown  
Controller

Countersignature Date:

3-6-18

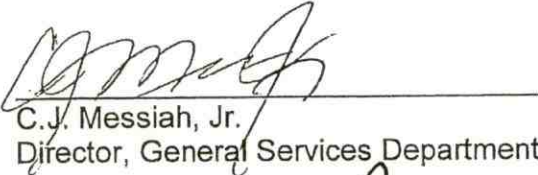

C.J. Messiah, Jr.  
Director, General Services Department

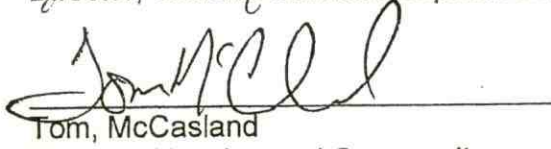

Tom, McCasland  
Director, Housing and Community  
Development Department

APPROVED AS TO FORM:

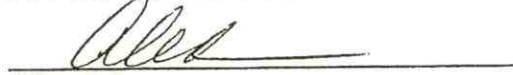

Alice Adam  
Senior Assistant City Attorney  
LD # 0331700069001

## EXHIBIT "A"

### PROJECT

#### TRACT 1

All of fractional Block Four Hundred Sixty-one (461) of the City of Houston, on the South Side of Buffalo Bayou in Harris County, Texas, more particularly described as follows:

BEGINNING at the Southeast corner of said Block 461, which is the Northwest corner of the intersection of Travis Street and Webster Avenue and which corner has Texas Lambert Coordinates, South Central Zone, of X=3,150,831.94 and Y=714,168.55;

THENCE N 57 deg. 05 min. 14 sec. W, called N 55 deg., W 94.40 feet along the North right-of-way line of Webster Avenue, based on a width of 80.00 feet, to a point for corner, said point being the Southwest corner of Block 461 and the Southeast corner of Block 21, of the HADLEY and FRANKLIN ADDITION;

THENCE N 20 deg. 28 min. 53 sec. E, called N 22 deg. 27 min. E, along the common West line of Block 461, SOUTH SIDE of BUFFALO BAYOU, and the East line of Block 21, of the HADLEY and FRANKLIN ADDITION, for a distance of 256.00 feet, called 255.99 feet, more or less, to a point for corner, said point being on the most Southerly right-of-way line of Gray Avenue, based on a width of 80.00 feet, said point also being the most Northwesterly corner of Block 461 of S.S.B.B. and the most Northeasterly corner of Block 21, of the HADLEY and FRANKLIN ADDITION;

THENCE along the most Southerly right-of-way line of Gray Avenue S 57 deg. 05 min. 14 sec. E, 149.51 feet, called S 55 deg. E, 149.7 feet, to a point for the intersection of the most Southerly right-of-way line of Gray Avenue and the most Westerly right-of-way line of Travis Street, for the most Northeasterly corner of the herein described tract, said point having Lambert coordinates of X=3,150,967.78 and Y=714,373.42 feet;

THENCE along the most Westerly right-of-way line of Travis Street, based on a width of 80.00 feet S 32 deg. 54 min. 46 sec. W, called S 35 deg. W, 250.00 feet to the POINT OF BEGINNING, and containing 30,488.8 square feet in all, more or less.

#### TRACT 2

A portion of fractional Block 21, HADLEY and FRANKLIN ADDITION, City of Houston, Harris County, Texas, and being more particularly described by metes and bounds, as follows:

BEGINNING at the most Southwesterly corner of said Block 21, which also is the intersection of the most Easterly right-of-way line of Milam Street and the most Northerly right-of-way line of Webster Avenue, both based on a width of 80.00 feet, said point has Texas Lambert Coordinates, South Central Zone, X=3,150,620.39 and Y=714,305.48;

THENCE along said Easterly right-of-way line of Milam Street, N 32 deg. 54 min. 46 sec. E, 121.61 feet, called approximately 125 feet, to a point for the Northwesterly corner of this tract;

THENCE S 57 deg. 05 min. 14 sec. E, 130.79 feet to a point for the most Northeasterly corner of the herein described tract;

THENCE S 20 deg. 28 min. 53 sec. W, 124.53 feet to a point on the most Northerly right-of-way

line of Webster Avenue, for the most Southeasterly corner of the herein described tract;

THENCE N 57 deg. 05 min. 14 sec. W, along the most Northerly right-of-way line of Webster Avenue for a distance of 157.60 feet, called 157 feet, to the POINT OF BEGINNING, and containing 17,535.6 square feet in all, more or less.

---

### Tract 3

BEING A TRACT OF LAND IN THE O. SMITH SURVEY ABSTRACT NO. 698, HARRIS COUNTY, TEXAS, A PORTION OF BLOCK 21 OF THE HADLEY AND FRANKLIN'S ADDITION, PER PLAT RECORDED IN VOLUME 2, PAGE 640 OF THE HARRIS COUNTY DEED RECORDS, ALL OF THAT LAND SOLD TO LEVAN REAL ESTATE, L.P., AS DESCRIBED IN A DEED RECORDED UNDER HARRIS COUNTY CLERK'S FILE NUMBER W263914, AND MORE PARTICULARLY DESCRIBED BY METES AND BOUNDS AS FOLLOWS WITH ALL BEARINGS BASED ON THE CENTERLINE OF MILAM STREET AS BEING N32°54'46"E. D

BEGINNING AT AN "X" SET IN CONCRETE MARKING THE INTERSECTION OF THE SOUTHEAST RIGHT-OF-WAY LINE OF MILAM STREET, 80 FEET WIDE, WITH THE SOUTHWEST RIGHT-OF-WAY LINE OF WEST GRAY AVENUE, 80 FEET WIDE, THE NORTH CORNER OF BLOCK 21 OF SAID HADLEY AND FRANKLIN'S ADDITION AND THE HEREIN DESCRIBED TRACT;

THENCE, S57°05'14"E, 102.49 FEET ALONG THE SOUTHWEST RIGHT-OF-WAY LINE OF SAID WEST GRAY AVENUE, AND THE NORTHEAST LINE OF SAID BLOCK 21 TO AN "X" SET IN CONCRETE MARKING THE NORTH CORNER OF A 0.6930 ACRE TRACT SOLD TO HDW 2000 1392 AVENUE LLC, AS DESCRIBED IN DEED RECORDED UNDER HARRIS COUNTY CLERK'S FILE NUMBER W457502, THE EAST CORNER OF SAID BLOCK 21 AND THE HEREIN DESCRIBED TRACT;

THENCE, S20°28'53"W, 131.47 (DEED CALL 131.37 FEET) FEET ALONG THE NORTHWEST LINE OF SAID 0.6930 ACRE TRACT, AND ALONG THE SOUTHEAST LINE OF SAID BLOCK 21 TO THE EAST CORNER OF A 0.4026 ACRE TRACT SOLD TO HDW 2000 1392 AVENUE LLC, AS DESCRIBED IN DEED RECORDED UNDER HARRIS COUNTY CLERK'S FILE NUMBER W457502, AND THE SOUTH CORNER OF THE HEREIN DESCRIBED TRACT;

THENCE, N57°05'14"W, 130.79 FEET ALONG THE NORTHEAST LINE OF SAID 0.4026 ACRE TRACT TO A 1/2 INCH IRON ROD FOUND MARKING A POINT IN THE SOUTHEAST RIGHT-OF-WAY LINE OF SAID MILAM STREET, THE NORTH CORNER OF SAID 0.4026 ACRE TRACT, AND THE WEST CORNER OF THE HEREIN DESCRIBED TRACT; A 1/2 INCH IRON ROD FOUND MARKING THE CENTERLINE CONTROL OF MILAM STREET BEARS N57°05'14"W, 40.0 FEET;

THENCE S32°54'46"W, 159.0 FEET;

THENCE, N32°54'46"E, 128.39 FEET ALONG THE SOUTHEAST RIGHT-OF-WAY LINE OF SAID MILAM STREET TO THE POINT OF BEGINNING, AND CONTAINING 14,976 SQUARE FEET OR 0.3438 ACRES, MORE OR LESS, OF LAND.

---



EXHIBIT "B"  
LEASED PREMISES

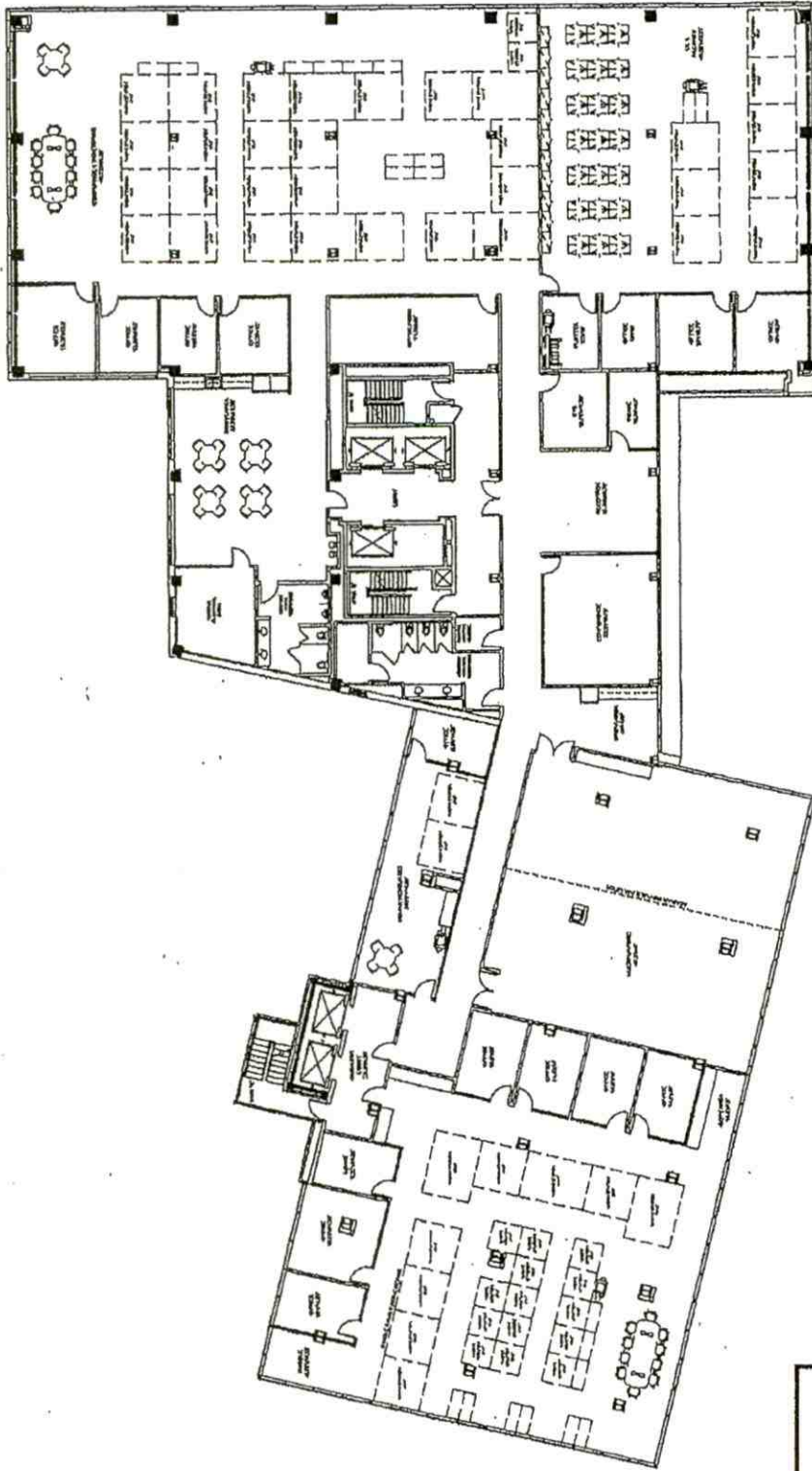

LEVEL 9

PROPOSED FLOOR PLAN

2100 TRAVIS STREET

**central square**

2100 TRAVIS STREET

15 1/30/18

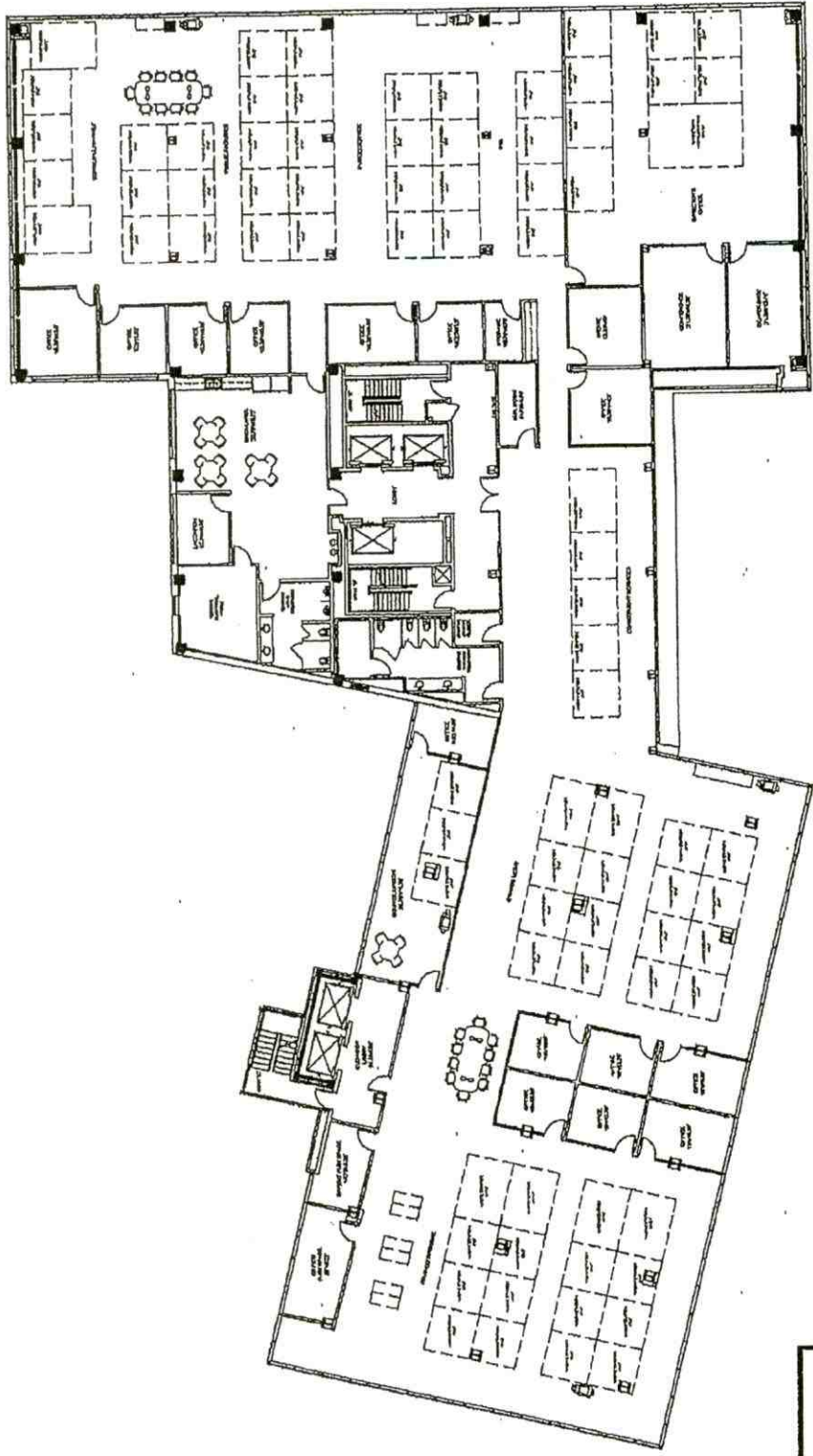

LEVEL 10  
*Sum*

PROPOSED FLOOR PLAN  
 2100 TRAVIS STREET  
 10/15/18



**central square**

2100 TRAVIS STREET

*B 1/30/18*

EXHIBIT "C"

CERTIFICATE OF COMMENCEMENT

To: City of Houston, Texas "Tenant"  
Attention: Rupa Sen  
General Services Department  
P.O. Box 61189  
Houston, Texas 77208-1189  
Facsimile 832/393-8061

From: Midtown Central Square, LLC "Landlord"  
Houston, Texas 770\_\_

Re: Leased Premises consisting of approximately 43,846 square feet of office space of the office building identified as 2100 Travis, Houston, Texas 77002.

Landlord hereby acknowledges to Tenant that the agreed-upon Tenant Improvements to the Leased Premises as required by the Lease have been Substantially Completed as of \_\_\_\_\_, 20\_\_.

By: \_\_\_\_\_  
Name: \_\_\_\_\_  
Title: \_\_\_\_\_  
Date: \_\_\_\_\_

Tenant hereby acknowledges to Landlord that the agreed-upon Tenant Improvements to the Leased Premises as required by the Lease have been Sustainably Completed as of \_\_\_\_\_, 20\_\_, and the Leased Premises is ready for occupancy by Tenant as of the date of the signature shown below.

By: \_\_\_\_\_  
C. J. Messiah Jr.  
Director  
General Services Department

Occupancy Date: \_\_\_\_\_

## EXHIBIT "D"

### TENANT SPECIFICATIONS ( Landlord is not responsible for providing or installing any furniture/work stations in the Leased Premises)

January 19, 2018  
General Services Department

Housing and Community Department (HCD)  
2100 Travis Houston, TX  
8<sup>th</sup> and 9<sup>th</sup> floors

- All specifications will pertain to the space plans submitted to the landlord.
- Contractor to abide by all current City, State and Federal Codes for the build out of the space.
- Contractor to permit all drawing and submit to City of Houston Code Enforcement and TAS for approval.
- Contractor to provide environmentally responsible practices that minimizes adverse effects on the exterior environment, enhances the quality of the indoor environment, and minimizes consumption of energy, water, construction materials, and other resources.
- Contractor to submit a set of complete plans to tenant for approval prior to submitting for permit for verification of all information.

#### I. DOORS

Number & location of doors to be designated by tenant.

1. All new doors and frames to be uniform to match throughout existing suite. Hardware to meet all ADA specifications.
2. All door hardware to include locks for securing office space. Landlord to provide keys and at least two master keys.
3. Install panic hardware on egress doors as needed per code.
4. Provide/install door closers at reception, storage and conference room areas. Provide and install door stops for all doorways.
5. Provide a lock on all entry & storage room doors. Computer room to have dead bolt lock. Lactation room to receive occupancy indicator deadbolt.
6. Door electric strike: ROFU 2400, stainless steel

#### II. WINDOWS

Mini blinds or equivalent building standard window coverings to be provided on all windows.

### III. INTERIOR WALL

1. Provide insulation in all Conference, Multi-purpose, Copy/Plotter, and Huddle/Quiet Rooms and extend walls up to deck.
2. Provide insulation in Restroom walls and extend walls up to deck.
3. Provide and install chair railing on conference room and waiting room walls.
4. Provide wall blocking in all IT closets, Conference and Multipurpose Rooms to support wall mounted equipment or monitor screens. Refer to plans for locations.
5. Office/conference walls facing corridor/open area: Raco (or equivalent) window framing system on top of a 4'-0" pony wall at 5/8" sheetrock each side of 3 5/8" metal studs.

### IV. FINISHES

#### WALLS:

Sample to be submitted for approval for any paint color selection.

1. All existing walls to receive one or more coats of paint as required to restore to new condition prior to move-in. Any existing or damage walls are to be repaired and painted to match new finishes. Sherwin Williams Paint or equal with low VOC rating. Paint samples to be submitted for approval.
2. Drywall finish at new walls to receive a level 4 finish
3. All existing corridors to receive new paint

#### FLOORING:

Sample to be submitted for approval for any new flooring required.

1. Install new rubber cove base at all new walls.
2. All VCT existing areas to be stripped and waxed. A minimum of 4 coats of wax to be applied prior to move in unless VCT specs state differently.

#### CEILING:

1. Open concept.
2. Minimum .75 NRC acoustical performance criteria for sound control in open plan areas.

### V. SIGNAGE

Tenant's chosen vendor to submit sign for approval by City and Landlord.

1. Signs are to be furnished and installed by Contractor.

## VI. MILLWORK

Length & location of cabinetry to be designated by tenant. Refer to plans.

1. Provide Break room and kitchenettes with plastic laminate counter with prefab (ready-made) base and wall cabinets.

## VII. SYSTEMS FURNITURE

1. Systems Furniture to be furnished per Tenant.
2. Contractor to coordinate with Systems Furniture vendor.
3. Contractor to follow General Specifications as per City provided specifications.

## VIII. ELEVATOR

1. Provide ADA elevator, where required, with access to all occupied levels. Elevator must meet ADA requirements.

## IX. FIRE PROTECTION

1. Provide Fire sprinkler system throughout the entire space with the system in the computer room (where applicable) to be a preaction type.

## X. PLUMBING

1. Provide Break rooms, kitchenettes, and lactation rooms with stainless steel sink with hot & cold water.
2. Provide all restroom fixtures, and drinking fountains, to comply with ADA, in numbers meeting current building codes.

## XII. HVAC

### THERMAL PERFORMANCE:

Provide heating & cooling system to condition the space to the following criteria:

Summer: Cool to 75 degrees with design condition of 92 degrees dry bulb/ 76 degrees wet bulb

Winter: Heat to a minimum of 70 degrees with a design condition of 0 degrees outside air temperature.

1. Contractor to verify that all HVAC units are functioning properly.
2. Re-work all duct (return and supply) as needed to satisfy new floor plan.
3. Verify all thermostats are working properly. Relocate as needed.
4. All electrical and plumbing to be installed for HVAC equipment to meet all City and State codes.

### XIII. ELECTRICAL

Tenant to review and approve final electrical floors plans prior to plan submittal.

**LIGHTING:** Provide recommended lighting power densities and energy performance criteria in accordance to the current code: 2015 IECC.

**POWER:**

- Work stations: Power connection to panel system with a capacity of 1 circuit per 3 work stations and empty conduit with a capacity for 2 data/comm. cables per work station.  
Stations to be powered off of a wall or column where applicable, floor boxes if in the center of an open area; no power poles unless with Tenants prior written approval.
  - Medium Offices: (up to 150 sq. ft.) 2 standard electrical duplex outlets & 1 empty box for data/comm. cables.
  - Large Offices: (over 150 sq. ft.) 3 standard electrical duplex outlets & 1 empty box for data/comm. cables.
  - Lg. Conference Rm. (over 500 sq. ft.) 6 standard electrical duplex outlets and, 4 empty boxes for data/comm. cables.; 1 centrally located floorbox
  - Multipurpose Rm: 10 standard electrical duplex and 4 empty boxes for data/comm. cables.
  - Other Conferences: 3 standard electrical duplex outlets & 1 empty box for data/comm. cables.
  - Provide power and an empty box for data/comm. cable to each copier, printer, and fax machine.
  - Reception area: 4 standard duplex elec, 1 data/comm.
  - Lactation room: 1 standard duplex
  - General Purpose: Provide convenience and cleaning outlets to be able to reach using a maximum of a 50' appliance cord.
1. Contractor to verify electrical service and panel capacity is adequate.
  2. Contractor to run and tie in all electrical whips for modular furniture per code. Furniture vendor is only responsible for providing electrical components.
  3. All new outlets to be installed at heights and locations per code.
  4. Verify electrical outlet locations per offices receiving system furniture.
  5. Provide life safety horn/strobes/alarm system as required by building code.
  6. Provide Exit signs and emergency lighting as required by building code.
  7. Provide electrical wiring runs at access control card-swipe entries.



#### XIV. PHONE AND DATA

All cable & wiring for telephones & computers is excluded; or performed by Landlord per Tenant's specifications and reimbursed by Tenant.

\*Refer to the City of Houston IT Telecommunications Cabling System Standards (dated June 25, 2015)

1. Landlord to provide phone service to the phone room to be used by the Tenant.
2. Contractor is responsible for providing empty data box and pull string.

#### XV. SECURITY

Landlord to coordinate with City of Houston Security for tenant floor access control system. Landlord is responsible for the installation of all security devices.

City of Houston Security to review and approve security/electrical drawings.

City of Houston Security to inspect security systems post construction.

1. Tenant to identify card-reader and ceiling mounted camera locations.

\*Refer to the City of Houston standard security devices product specifications (dated January 19, 2018)

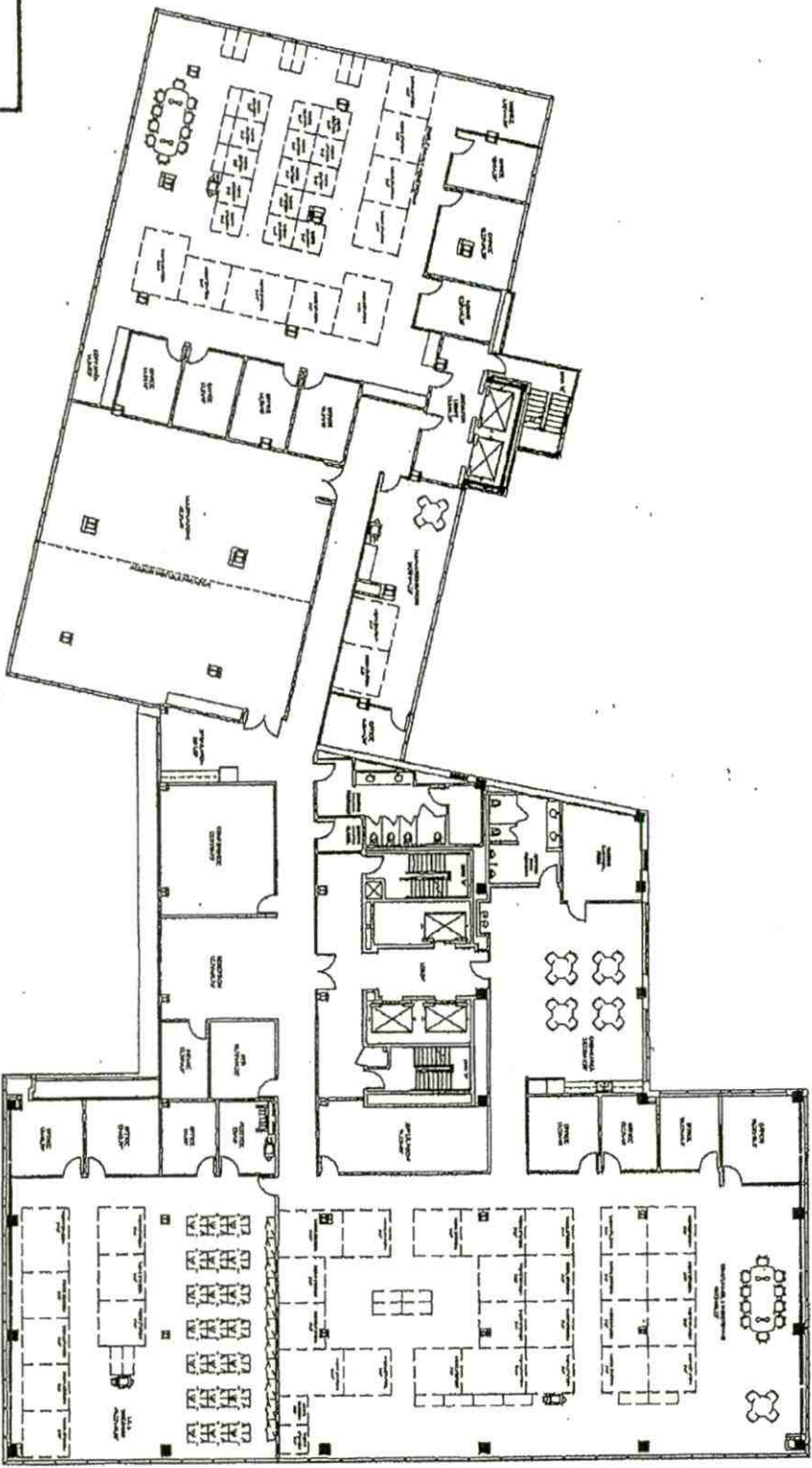

**central square**

2100 TRAVIS STREET

PROPOSED FLOOR PLAN

B 1/3d/18



10  
9

B  
1/30/18

central  
square

2100 TRAVIS STREET

PROPOSED FLOOR PLAN

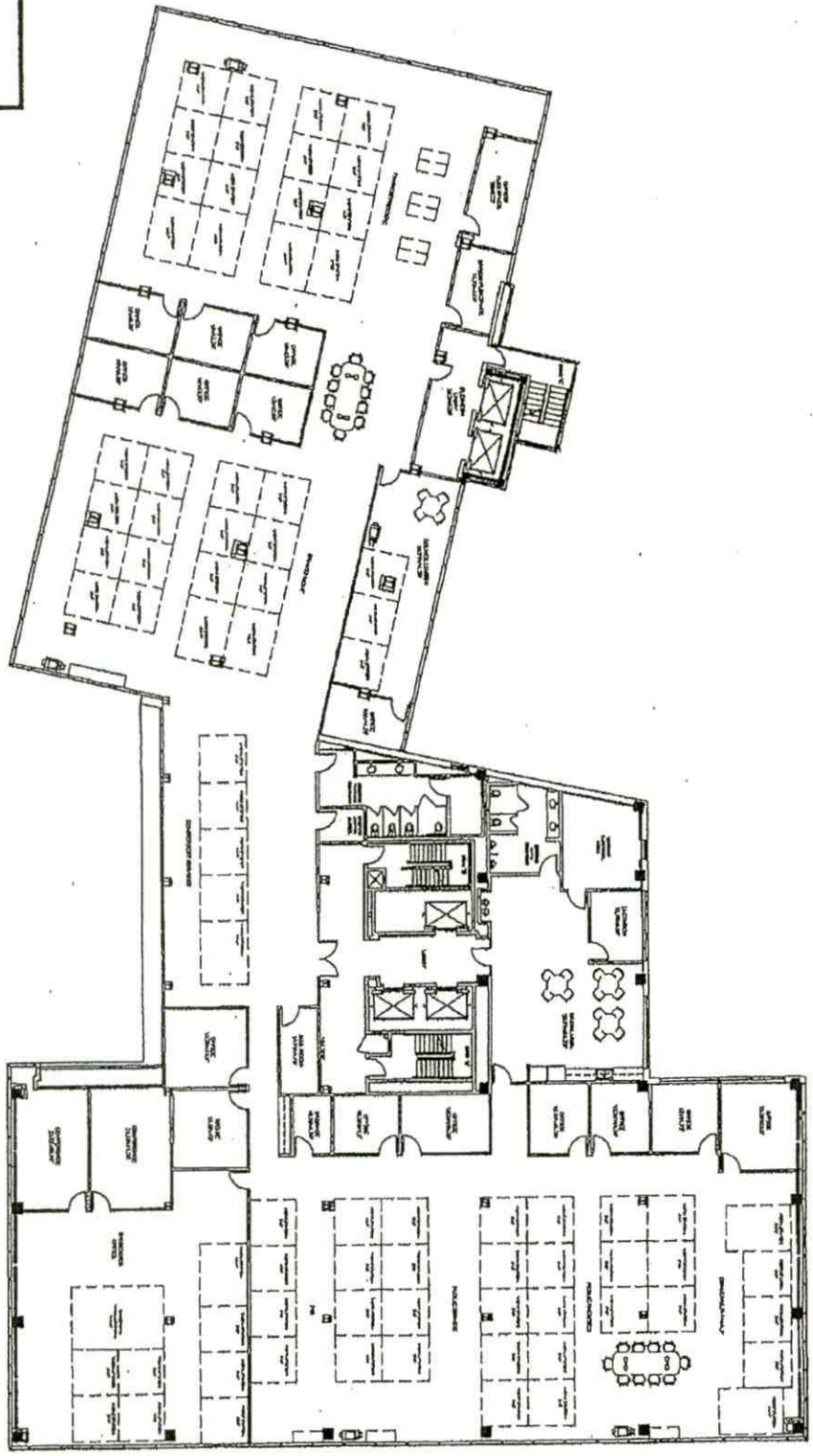

LEVEL  
10

THIS FLOOR PLAN IS THE PROPERTY OF THE ARCHITECT AND IS NOT TO BE REPRODUCED OR COPIED IN ANY MANNER WITHOUT THE WRITTEN PERMISSION OF THE ARCHITECT.



PHYSICAL ACCESS SOLUTIONS

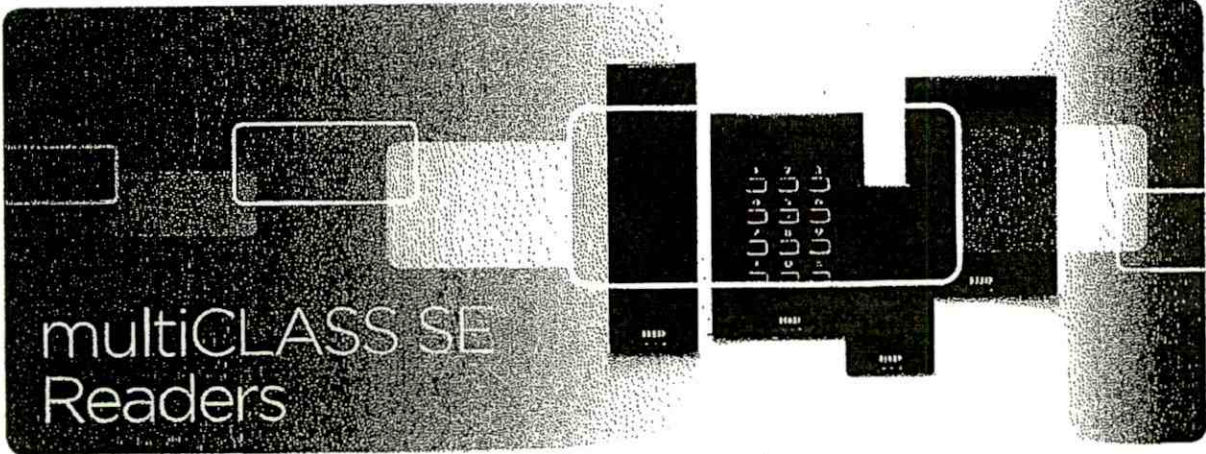

HIGHLY ADAPTABLE AND SECURE HIGH FREQUENCY ACCESS CONTROL SOLUTION

- **Powerfully Secure** - Provides layered security beyond the card media for added protection to identity data using SIOs.
- **Adaptable** - Interoperable with a growing range of technologies and form factors including mobile devices utilizing Seos™.
- **Interoperable** - Open Supervised Device Protocol (OSDP) for secure, bidirectional communication.
- **Streamlined Migration** - Simultaneous support for 125 kHz HID Prox®, AWID and EM4102 for seamless migration; field programmable for secure upgrades and extended lifecycle.

HID Global's ICLASS SE® platform goes beyond the traditional smart card model to offer a secure, standards-based and flexible platform that has become the new benchmark for highly adaptable, interoperable and secure access control solutions.

MIFARE DESFire EV1 with custom data models and other leading technologies.

Additionally, multiCLASS SE readers support mobile devices utilizing Seos, enabling a new class of portable identity credentials that can be securely provisioned and safely embedded into both fixed and mobile devices.

multiCLASS SE® readers simplify migration from legacy technologies with support 125 kHz for HID Prox, Indala, AWID and EM4102, and provide customers the assurance that their existing investments can be leveraged to enhance their system as business requirements change. The technology-independent readers also support ICLASS® Seos™ and ICLASS SE credential platforms, as well as standard ICLASS, MIFARE and

As part of HID® Global's ICLASS SE platform that is based on the Secure Identity Object™ (SIO®) data model and Trusted Identity Platform™ (TIP™), the powerfully secure multiCLASS SE readers offer advanced features such as layered security beyond the card media and tamper-proof protection of keys/cryptographic operations using EALS+ secure element hardware.

multiCLASS SE readers include Open Supervised Device Protocol (OSDP), a new Security Industry Association (SIA) standard that together with Secure Channel Protocol (SCP) provides secure communications and central management.

**POWERFULLY SECURE:**

- Multi Layered Security - Enhances user identity and privacy through the multi-layered security of SIO & Seos.
- EALS+ Certified Secure Element Hardware - Provides tamper-proof protection of cryptographic operations.
- SIO Data Binding - Helps to bind identity and/or object to a secure credential.
- Encrypted communication using OSDP with Encrypted Channel Protocol.

**HIGHLY ADAPTABLE:**

- Flexible form factor support - Easy card reader or handheld, fixed access for indoor.
- SIO Portability - Provides the ability to migrate from one SIO platform to another.
- Interoperable - Provides compatibility with all standard and custom access control systems to extend your investment.
- Field Programmable Reader - Provides secure migration to migration and extended lifecycle.

**SUSTAINABILITY AND MANAGEMENT:**

- Intelligent Power Management (IPM) - Reduces power consumption by up to 75% - saves power, lowers operating costs.
- Tamper-Proof - Tamper-proof hardware to ensure data integrity.

**INTEROPERABLE:**

- SIO Media Mapping - Simplifies deployment of new SIOs, connects to multiple SIOs.
- Incompatibility - Incompatibility with other SIOs.
- Custom programming support to add custom data models on MIFARE and MIFARE DESFire EV1.

**FUNCTIONALITY AND MANAGEMENT:**

- Tamper-Proof - Tamper-proof hardware to ensure data integrity.
- SIO Media Mapping - Simplifies deployment of new SIOs, connects to multiple SIOs.
- Incompatibility - Incompatibility with other SIOs.
- Custom programming support to add custom data models on MIFARE and MIFARE DESFire EV1.



## SPECIFICATIONS

Base Part Number	RP10	RP15	RP40	RPK40
	900P 900L	910P	920P 920L	921P 921L
Typical Read Range <sup>1</sup>	ICLASS Seos: 1.2" (3 cm) ICLASS: 3.1" (8 cm) MIFARE Classic: 2.8" (7 cm) MIFARE DESFire EV1: 1.2" (3 cm)	ICLASS Seos: 1.2" (3 cm) ICLASS: 3.1" (8 cm) MIFARE Classic: 2.8" (7 cm) MIFARE DESFire EV1: 1.2" (3 cm)	ICLASS Seos: 2.0" (5 cm) ICLASS: 4.7" (12 cm) MIFARE Classic: 4.7" (12 cm) MIFARE DESFire EV1: 2.0" (5 cm)	ICLASS Seos: 1.6" (4 cm) ICLASS: 4.7" (12 cm) MIFARE Classic: 4.3" (11 cm) MIFARE DESFire EV1: 1.6" (4 cm)
	ICLASS: 1.6" (4 cm) MIFARE Classic: 1.2" (3 cm)	ICLASS: 1.6" (4 cm) MIFARE Classic: 1.2" (3 cm)	ICLASS: 2.4" (6 cm) MIFARE Classic: 2.0" (5 cm)	ICLASS: 2.8" (7 cm) MIFARE Classic: 1.6" (4 cm)
	HID Prox: 2.8" (7 cm) Indala Prox: 1.6" (4 cm) EM4102 Prox: 4.3" (11 cm)	HID Prox: 2.8" (7 cm) Indala Prox: 1.6" (4 cm) EM4102 Prox: 4.3" (11 cm)	HID Prox: 2.8" (7 cm) Indala Prox: 2.0" (5 cm) EM4102 Prox: 4.3" (11 cm)	HID Prox: 2.8" (7 cm) Indala Prox: 2.0" (5 cm) EM4102 Prox: 3.1" (8 cm)
	HID Prox: 1.6" (4 cm) Indala Prox: 0.8" (2 cm) EM4102 Prox: 2.8" (7 cm)	HID Prox: 2.0" (5 cm) Indala Prox: 0.8" (2 cm) EM4102 Prox: 2.8" (7 cm)	HID Prox: 2.0" (5 cm) Indala Prox: 1.2" (3 cm) EM4102 Prox: 2.8" (7 cm)	HID Prox: 1.6" (4 cm) Indala Prox: 1.2" (3 cm) EM4102 Prox: 2.4" (6 cm)
Mounting	Mini-Mullion Size; physically HID's smallest ICLASS readers and are ideally suited for mullion-mounted door installations, U.S. single-gang J-box (with mud ring) or any flat surface	Mullion Size; physically HID's second smallest ICLASS readers and are ideally suited for mullion-mounted door installations, U.S. single-gang J-box (with mud ring) or any flat surface	Wall Switch Size; designed to mount and cover single gang switch boxes primarily used in the Americas and includes a slotted mounting plate for European and Asian back box spacing	
Color	Black			
Keypad	No			
Dimensions	1.9" x 4.1" x 0.9" 4.8 cm x 10.3 cm x 2.3 cm	1.9" x 6.0" x 0.9" 4.8 cm x 15.3 cm x 2.3 cm	3.3" x 4.8" x 1.0" 8.4 cm x 12.2 cm x 2.4 cm	3.3" x 4.8" x 1.1" 8.5 cm x 12.2 cm x 2.8 cm
Product Weight (Platt)	4.0oz (114g)	5.2oz (148g)	7.8oz (222g)	9.1oz (259g)
Product Weight (Terminal Strip)	3.0oz (85g)	4.3oz (124g)	7.6oz (216g)	8.0oz (228g)
Operating Voltage Range	5-16 VDC, Linear supply recommended			
Current Draw - Standard Power Mode <sup>2</sup> (mA)	75	75	85	95
Current Draw - Intelligent Power Management (IPM) Mode <sup>2</sup> (mA)	40	40	50	70
Peak Current Draw - Standard Power or IPM Mode <sup>2</sup> (mA)	200	200	200	200
NSC <sup>3</sup> Power Consumption - Standard Power Mode (W @ 16VDC)	1.2	1.2	1.4	1.5
NSC <sup>3</sup> Power Consumption - w/ IPM (W @ 16VDC)	0.6	0.6	0.8	1.1
Operating Temperature	-31° to 150° F (-35° to 65° C)			
Storage Temperature	-67° to 185° F (-55° to 85° C)			
Operating Humidity	5% to 95% relative humidity non-condensing			
Environmental Rating	Indoor/Outdoor IP55; IP65 if installed with optional gasket (IP65GSKT)			
Transmit Frequency	13.56 MHz & 125 kHz			
13.56 MHz Card Compatibility	Secure Identity Object™ (SIO™) on ICLASS Seos, ICLASS SE/SR, MIFARE DESFire EV1 and MIFARE Classic (On by Default) - standard ICLASS Access Control Application (order with Standard Interpreter) - ISO14443A (MIFARE) CSN, ISO14443B CSN, ISO15693 CSN - MIFARE Classic and MIFARE DESFire EV1 custom data models - Felica™ CSN, CEPAS™ CSN or CAN			
125 kHz Card Compatibility	HID Prox™, AWID™, Indala, EM4102™			
Communications	Optional OSDP with SCP over RS485 <sup>4</sup> Wiegand/Clock-and-Data Interface SOCr (150m) (22AWG) - Use shielded cable for best results			
Panel Connection	Platt or Terminal Strip			
Certifications	UL294/cUL (US), FCC Certification (US), IC (Canada), CE (EU), C-Tick (Australia, New Zealand), SRRC (China), MIC (Korea), NCC (Taiwan), IDA (Singapore), RoHS, FIPS-201 Transparent FASC-N Reader			
Crypto Processor Hardware Common Criteria Rating	EAL5+			
Patents	US7180403, US7439862, US7124943, US5952935, US6058481, US6337819			
Housing Material	UL94 Polycarbonate			
Manufactured with % of recycled content (Platt)	10.5%	11.0%	10.5%	10.9%
Manufactured with % of recycled content (Terminal Strip)	10.5%	11.0%	11.0%	12.3%
UL Ref Number	RP10E	RP15E	RP40E	RPK40E
Warranty	Limited Lifetime			

<sup>1</sup> Read range listed is statistical mean rounded to nearest whole centimeter. HID Global testing occurs in open air. Some environmental conditions, including metallic mounting surfaces, can significantly degrade read range and performance. Plastic or ferrite spacers are recommended to improve performance on metallic mounting surfaces.  
<sup>2</sup> Measured in accordance with UL294 standards; see Installation Guide for Details.  
<sup>3</sup> NSC = Normal Standby Current; see Installation Guide for Details.  
<sup>4</sup> Not available on SSKL part numbers.



North America: +1 512 776 9000  
 Toll Free: 1 800 237 7769  
 Europe, Middle East, Africa: +44 1440 714 850  
 Asia Pacific: +852 3160 9800  
 Latin America: +52 55 5081 1650

hidglobal.com

### ASSA ABLOY

An ASSA ABLOY Group brand

© 2016 HID Global Corporation. All rights reserved. HID, the HID logo, mullion, ICLASS SE, ICLASS SE, ICLASS Seos, Indala, HID Prox, Secure Identity Object, SIO, Turned Identity Platform, TIP, and ICLASS Elite are trademarks or registered trademarks of HID Global in the U.S. and/or other countries. All other trademarks, service marks, and product or service names are trademarks or registered trademarks of their respective owners. 2016-05-16-hid-mullion-ic-se-readers-on-PLT-00303

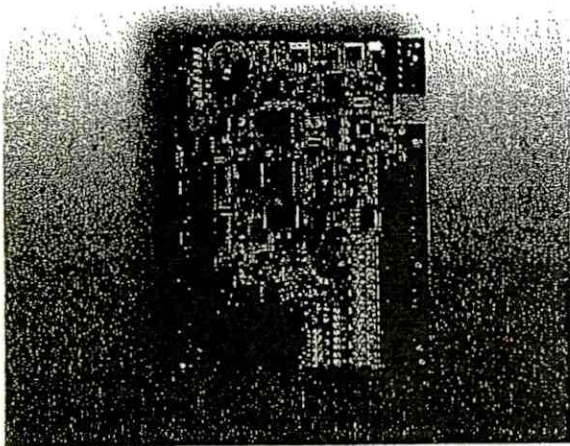

## Power for the Enterprise



### SSP-D2 Features

- Native on-board 10/100 Ethernet for up to 10x faster throughput than traditional serial connections
- DHCP and static IP addressing support
- Built-in control for 2 access control doors (2 reader ports, 4 Form-C relay outputs, 8 supervised inputs)
- Standard 6 MB available non-volatile flash memory stores up to 250,000 cardholders\*
- Background firmware downloads with system configuration restored from flash memory for seamless updates.
- Storage and backup for 50,000 events
- 12 or 24 VDC input voltage
- Biometric template management
- AES 128-bit encryption option for host communications
- On-board readers support mag, Wiegand, and OSDP 485 readers and keypads
- Support for multiple card formats
- Diagnostic LEDs
- Dedicated inputs for tamper and power failure alarms
- Improved Area management and Anti-passback support
- Precision Access
- Elevator Control up to 128 floors
- If/Then Macro functionality

\* Based on estimated values and memory allocation options.

## SSP-D2

*Open Options  
Intelligent Two Door Controller*

### Overview

The Open Options **SSP-D2** is a native IP-ready intelligent controller with a built-in reader interface module allowing control of two doors right off the board and a total of 64 using additional reader and/or IO modules.

The **SSP-D2** connects directly to the LAN and supports the new Open Supervised Device Protocol (OSDP) for bidirectional communication to RS-485 and biometric devices.

The integrated 10/100 Ethernet port not only means faster more efficient connections to the host, but also less equipment and connections to manage compared to earlier generation panels. Connecting over IP is simplified using DHCP for auto-assigning IP addresses and device name recognition for easy management with a DNS server.

When used in conjunction with DNA Fusion™, the Open Options **SSP-D2** is the perfect solution that is scalable for any access control application.



# SSP-D2 Controller

## Specification

<p><b>Primary Power</b> DC Input:</p> <p><b>Memory and Clock Backup</b></p> <p><b>Communication</b> Primary (Ethernet) Port: Alternate Upstream Port 1: Downstream Port 2:</p> <p><b>Inputs</b> Tamper and Power Monitors: Door status, REX, and AUX:</p> <p><b>Outputs</b> Relay outputs: Reader Ports DC output:</p> <p>Reader Compatibility</p> <p><b>Environmental</b> Temperature:</p> <p>Humidity:</p> <p><b>Mechanical</b> Dimensions: Weight: Listings/Approvals</p>	<p>The SSP-D2 is for use in low voltage, power-limited, class 2 circuits only. 12 or 24 VDC <math>\pm</math> 10%. 500 mA maximum (reader current not included) 12Vdc @ 250mA (plus reader current) nominal 24Vdc @ 150mA (plus reader current) nominal 3 V Lithium, type BR2325, BR2330, CR2330</p> <p>10/100Base-T Ethernet high-speed port RS-232 9600 to 115.2 Kbps async RS-485 (2-wire) 9600 to 38.4 Kbps async</p> <p>Unsupervised, dedicated 8 programmable inputs (normally open/closed/supervised/non-supervised)</p> <p>4 Form-C 5 A at 30 VDC relay outputs (user-defined as strike or AUX)</p> <p>12VDC<math>\pm</math>10% regulated, current limited to 150mA for each reader OR 12 to 24VDC<math>\pm</math>10% (pass through) current limited to 150mA per reader Wiegand Data1/Data0, Magnetic Clock/Data, OSDP Compatible Devices (Open Supervised Device Protocol RS-485)</p> <p>Operating: 0° to 70° C (32° to 158° F) Storage: -55° to 85° C (-67° to 185° F) 0 to 95% RHNC</p> <p>6 x 8 x 1 in. (152 x 203 x 25 mm) 9 oz. (255 g) nominal UL Recognized Component ROHS-compliant Advanced Encryption Standard (AES) 128-bit communication algorithm</p>
--	---

## Application

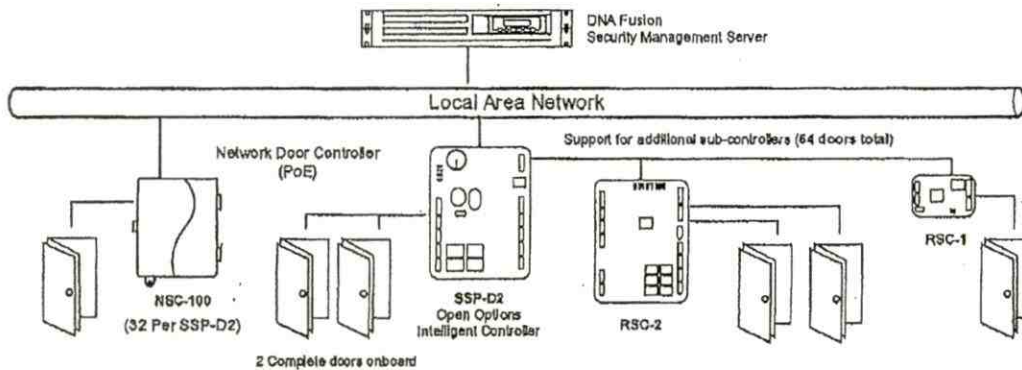

tel: 972.818.7001  
fax: 972.818.7003  
www.ooaccess.com

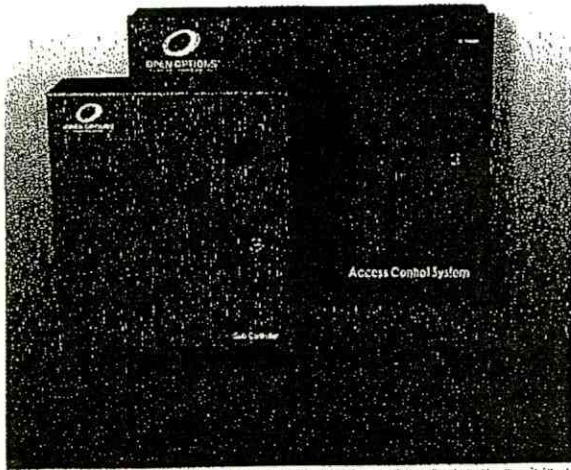

**Ready to Install**  
Quick. Simple. Convenient.



### Enclosed Product Features

Single-source solution eliminates cost of multiple part vendors, orders and payments.

Dramatically reduces time associated with field construction of panel enclosures.

Provides standard and consistent field wiring of controllers and sub-controllers across all projects for easy service.

Overall enhanced profitability through simplified sales, order entry, and installation.

Pre-wired for quick and simple installation.

Automatic switch over to backup battery in applicable units.

Cabinet tamper switch comes standard on all enclosure assemblies.

Sub-controller enclosures are compact and convenient for above-door installation.

All enclosures are certified with MET Labs and comply with UL 294 standard.

## Enclosed Products

*Open Options Pre-wired Assemblies*

### Overview

Open Options Enclosed Products deliver a complete solution for security integrators wanting to provide quality, flexible, ready-to-install panel enclosures on all their projects. Both the E2 Series enclosure and the Sub-controller enclosures offer a wide variety of configuration options to meet the needs of the open architecture system and provide a professionally consistent image on every project.

The **E2 Series Enclosure** comes complete with a power supply, power distribution board, and tamper switch. The E2 Enclosure is extremely flexible and can be ordered with any combination of boards with enough power to handle additional downstream devices.

**Sub-controller Enclosures** come in two basic forms. The standard "C" enclosure is a 12" x 14" assembly that consists of any single sub-controller panel that is pre-wired to a terminal strip and a tamper switch.

The **E3 Series Enclosure** is available with any combination of two sub-controller boards pre-wired to a terminal strip in a 16" x 20" metal enclosure with a tamper switch.



**OPEN OPTIONS**  
— ACCESS TECHNOLOGY —



# Enclosed Products

## E2 Series Enclosure

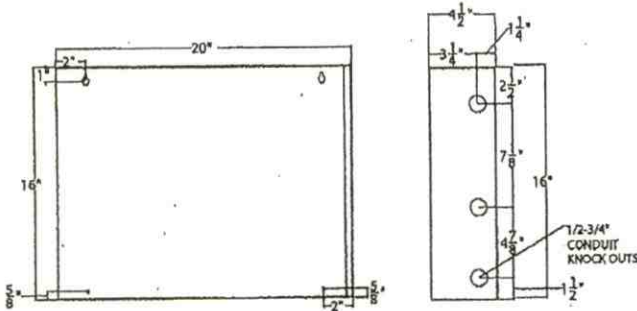

- 16" x 20" metal enclosure with removable cover and key slot mounting holes.
- SPS-10 Power Supply with Universal AC Input (85-264VAC) and 12VDC output (8 continuous amps).
- Self contained transformer.
- Built in charger for battery backup.
- Power distribution board provides 8 class II power limited outputs.
- Micro tamper switch and key lock.
- MET Labs certified - UL 294 compliant
- Available with any combination of Open Options intelligent controllers or sub-controllers.

## "C" Enclosure

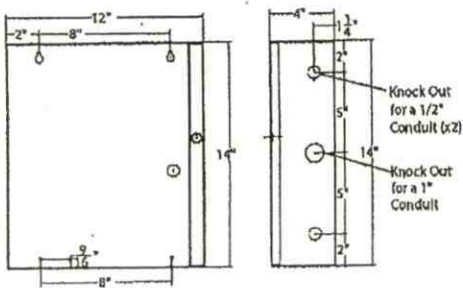

- 12" x 14" metal enclosure with removable cover and key slot mounting holes.
- Knock outs for 1/2" and 1" conduit.
- Most configurations come pre-wired to a 24 position terminal strip for added convenience and easy installation.
- MET Labs certified - UL 294 compliant.
- Micro tamper switch and key lock.
- Available with any combination of Open Options sub-controllers.

## E3 Series Enclosure

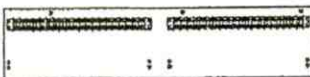

The E3 Series is the same basic enclosure as the E2 without power supply and distribution.

- Most configurations come pre-wired to (2) 24 position terminal strips for added convenience and easy installation.
- MET Labs certified - UL 294 compliant.
- Micro tamper switch and key lock.
- Available with any combination of Open Options sub-controllers.



tel: 972.818.7001  
 fax: 972.818.7003  
 www.oocaccess.com

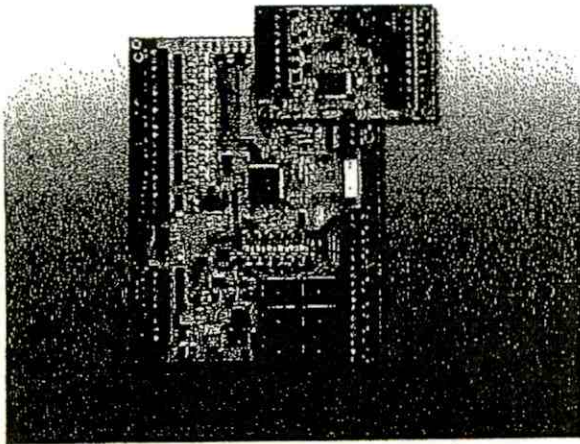

## Door Modules

Reliable. Versatile. Secure.

ROHS  
COMPLIANT



### RSC-2- Dual Reader

- Support for proximity, magnetic stripe, Wiegand, RS-485 and keypad readers
- 8 programmable inputs support normally open, normally closed, supervised and non-supervised circuits
- 6 relay outputs can be set for fail safe or fail secure operation
- Stores up to 8 facility codes for basis of access decisions in offline mode
- Speeds up to 38,400 bits per second

### RSC-1- Single Reader

- Support for proximity, magnetic stripe, Wiegand, RS-485 and keypad readers
- 2 programmable inputs support normally open, normally closed, supervised and non-supervised circuits
- 2 relay outputs can be set for fail safe or fail secure operation
- Stores up to 8 facility codes for basis of access decisions in offline mode
- Speeds up to 38,400 bits per second

## RSC-1 & RSC-2

Reader Sub-controllers

### Overview

Reader Sub-controllers provide the interface between door devices and the SSP™ Series Controllers.

Both RSC devices support a multitude of magnetic stripe, Wiegand, RS-485 and proximity readers, as well as providing I/O support for door devices such as request to exits and door contacts.

The RSC-2 supports two readers for two completely separate doors or an in/out configuration. The RSC-2 also includes inputs and outputs beyond the requirements for a typical door configuration allowing for system expansion without the added cost.

The RSC-1 is the perfect solution for almost any single door configuration and has an extra relay output for auxiliary device control.



**OPEN OPTIONS™**  
ACCESS TECHNOLOGY

# Reader Modules

## RSC-1

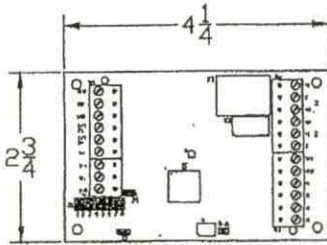

RSC-1

**Primary Power** 12 to 24VDC  $\pm$  10%, 12VDC @ 110mA (plus reader current) nominal, 24VDC @ 60mA (plus reader current) nominal

**Wiring Specifications**  
 Power: 1 twisted pair, 18 AWG min.  
 RS-485: 22 AWG, 4,000ft (1,200m) max., twisted pair with shield

**Reader Ports**  
 Power: 12 to 24VDC  $\pm$  10% (input voltage passed through)  
 LED: TTL compatible, high >3V, low <0.5V, 5mA sink max.  
 Buzzer: Open collector, 5VDC open circuit max, 10mA sink max.  
 Reader: TTL compatible inputs or 2-wire 485

**Inputs/Outputs**  
 2 General purpose: Programmable circuit type  
 1 dedicated: Tamper  
 Relay 1: Form-C, 5A 28 VDC  
 Relay 2: Form-C, 1A 28 VDC

**Environmental**  
 Temperature: -40 to 70C operational, -55to 85C storage  
 Humidity: 10% to 95% RHNC

**Mechanical**  
 Dimensions: 4.25 in. W x 2.75 in. L x 1.0 in. H (108mm W x 70mm L x 25.4mm H)  
 Weight: 4 oz. (120gm) nominal  
 Listing: UL Listed ALVY2, CE

## RSC-2

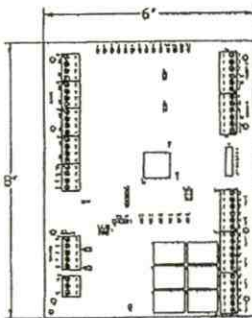

RSC-2

**Primary Power** 12 to 24VDC  $\pm$  10%, 12VDC @ 450mA (plus reader current) nominal, 24VDC @ 270mA (plus reader current) nominal

**Wiring Specifications**  
 Power: 1 twisted pair, 18 AWG min.  
 RS-485: 22 AWG, 4,000ft (1,200m) max., twisted pair with shield

**Reader Ports**  
 Power: 12 VDC  $\pm$  10% regulated, 125mA max each reader OR 12 VDC  $\pm$  10% (voltage passed through), 125mA max each reader  
 All other reader port specifications are same as RSC-1 (see above),

**Inputs/Outputs**  
 8 General purpose: Programmable circuit type  
 2 dedicated: 1 tamper and 1 power monitor each  
 6 Relays: Form-C, 5A @ 28VDC, resistive

**Environmental**  
 Temperature: 0 to 70C operational, -55to 85C storage  
 Humidity: 0 to 95% RHNC

**Mechanical**  
 Dimensions: 6 in. W x 8 in. L x 1.0 in. H (152mm W x 203mm L x 25mm H)  
 Weight: 11 oz. (312gm) nominal  
 Listing: UL Listed ALVY2, CE

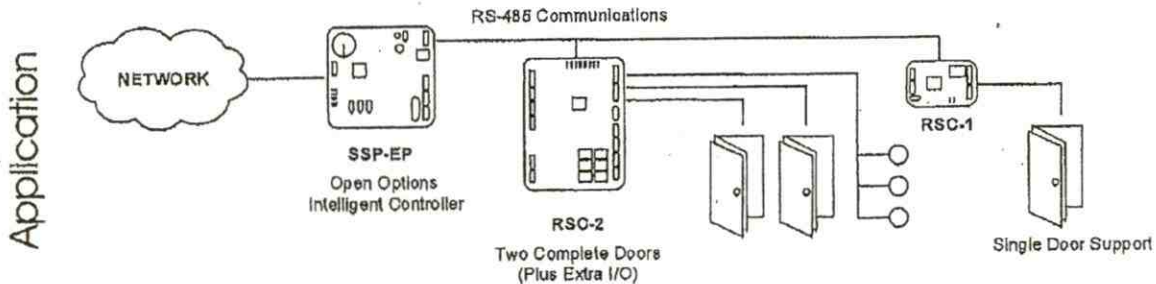

Application



tel: 972.818.7001  
 fax: 972.818.7003  
 www.ooaccess.com

**ROFU® ELECTRIC STRIKE  
MODEL 2400 Kit**

Replaces the 2402 & 2404 Series

SECURITY



*The Do it all Strike!*



**Model 2400 KIT - Fail - Safe / Fail - Secure**

Electric strikes for use with mortise and cylindrical locksets.  
For Commercial and Residential, New and Retrofit Uses.

**STANDARD FEATURES**

- Both Stainless Steel Faceplates
- 12/24 dual Voltage
- Frame Type - Hollow Metal, Aluminum or Wood
- Corrosion - Resistant case and moving parts.
- Tamper Strength Test - 1500 lbs. (700kg)
- Cycle Test 1,000,000 cycles
- Keeper Depth - 1/2", Maximum Latch Projection possible with 1/8" Door/Frame Clearance - 5/8"
- Strike Depth - 1.1/4" Overall
- Reversible - Non Handed
- Stainless Steel Keeper
- Limited Warranty - 36 Months
- Easily converts from fail safe to fail secure and back.
- UL Listed for Burglary Protection - BP3741

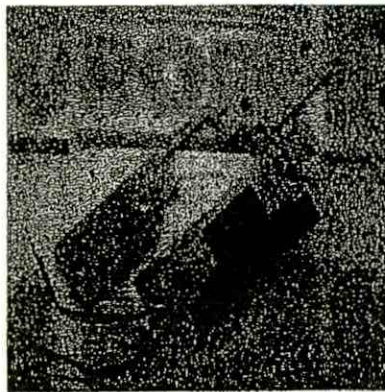

Line Art

Installation Drawing  
Hollow Metal

Optional Features	
Monitor Switch	Still remains series specific 2402x05LM, 2402x08LM or 2404x05LM, 2404x08LM
1" Lip Extension, specify #5525.	2" Lip Extension, specify #5550.

**2402 SERIES - LINE ART (please see 2404 for longer faceplate)**

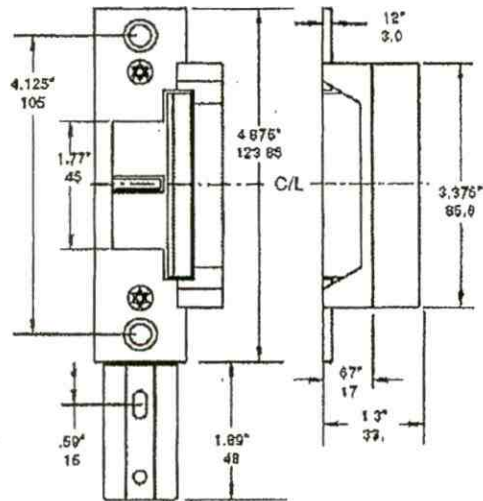

Note: Not to scale. Technical Data are subject to change without notice.  
Dimensions in Inches and Millimeters

**2402 - Series Installation (please see 2404 for longer faceplate)  
Hollow Metal Jamb**

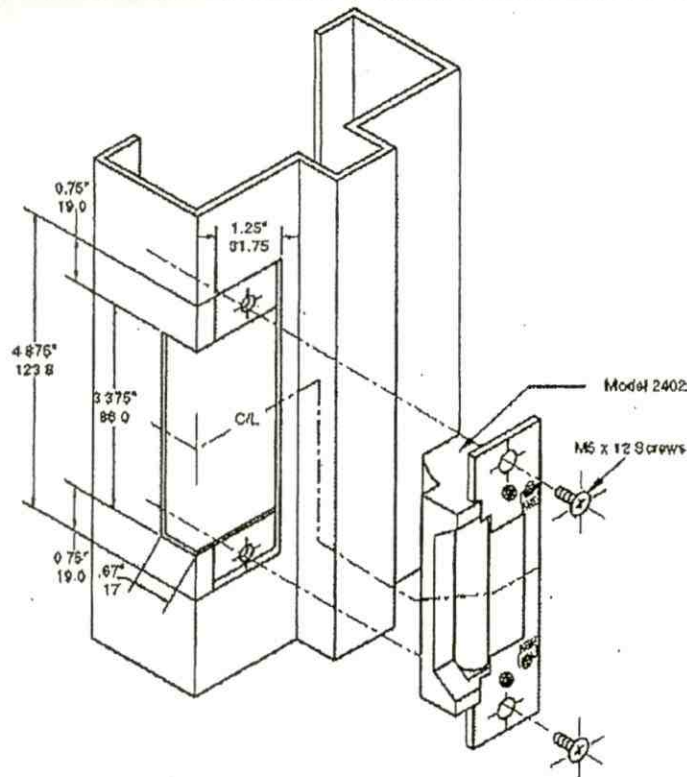

[Download pdf file](#)

Note: Not to scale. Technical Data are subject to change without notice.

Video | FLEXIDOME IP outdoor 5000 HD

# FLEXIDOME IP outdoor 5000 HD

www.boschsecurity.com



**BOSCH**  
Invented for life



- ▶ 1080p resolution for sharp images
- ▶ Easy to install with auto zoom/focus lens, wizard and pre-configured modes
- ▶ Fully configurable quad streaming
- ▶ Regions of Interest and E-PTZ
- ▶ IR version with 15 m (50 ft) viewing distance

The 1080p outdoor dome cameras from Bosch are professional surveillance cameras that provide high quality HD images for demanding security and surveillance network requirements. These robust domes are true day/night cameras offering excellent performance day or night.

There is a version with a built-in active infrared illuminator that provides high performance in extreme low-light environments.

## System overview

**Vandal resistant outdoor dome with varifocal lens**  
Ideal for outdoor use, the IK10-rated design is suitable for installations where a vandal resistance is important. The camera is protected against water and dust to IP66 standards. The varifocal lens allows you to choose the coverage area to best suit your application. Mounting options are numerous, including surface, wall, and suspended-ceiling mounting. The automatic zoom/focus lens wizard makes it easy for an installer to accurately zoom and focus the camera for both day and night operation. The wizard is activated from the PC or from the on-board camera push button making it easy to choose the workflow that suits best.

The AVF (Automatic Varifocal) feature means that the zoom can be changed without opening the camera. The automatic motorized zoom/focus adjustment with 1:1 pixel mapping ensures the camera is always accurately focused.

## Functions

### Intelligent Dynamic Noise Reduction reduces bandwidth and storage requirements

The camera uses Intelligent Dynamic Noise Reduction which actively analyzes the contents of a scene and reduces noise artifacts accordingly.

The low-noise image and the efficient H.264 compression technology provide clear images while reducing bandwidth and storage by up to 50% compared to other H.264 cameras. This results in reduced-bandwidth streams that still retain a high image quality and smooth motion. The camera provides the most usable image possible by cleverly optimizing the detail-to-bandwidth ratio.

**Area-based encoding**

Area-based encoding is another feature which reduces bandwidth. Compression parameters for up to eight user-definable regions can be set. This allows uninteresting regions to be highly compressed, leaving more bandwidth for important parts of the scene.

**Bitrate optimized profile**

The average typical optimized bandwidth in kbits/s for various image rates is shown in the table:

IPS	1080p	720p	480p
30	1600	1200	600
15	1274	955	478
12	1169	877	438
5	757	568	284
2	326	245	122

**Multiple streams**

The innovative multi-streaming feature delivers various H.264 streams together with an M-JPEG stream. These streams facilitate bandwidth-efficient viewing and recording as well as integration with third-party video management systems.

Depending on the resolution and frame rate selected for the first stream, the second stream provides a copy of the first stream or a lower resolution stream.

The third stream uses the I-frames of the first stream for recording; the fourth stream shows a JPEG image at a maximum of 10 Mbit/s.

**Regions of Interest and E-PTZ**

Regions of Interest (ROI) can be user defined. The remote E-PTZ (Electronic Pan, Tilt and Zoom) controls allow you to select specific areas of the parent image. These regions produce separate streams for remote viewing and recording. These streams, together with the main stream, allow the operator to separately monitor the most interesting part of a scene while still retaining situational awareness.

**Two-way audio and audio alarm**

Two-way audio allows the operator to communicate with visitors or intruders via an external audio line input and output. Audio detection can be used to generate an alarm if needed.

**Tamper and motion detection**

A wide range of configuration options is available for alarms signaling camera tampering. A built-in algorithm for detecting movement in the video can also be used for alarm signaling.

**Storage management**

Recording management can be controlled by the Bosch Video Recording Manager (VRM) or the camera can use iSCSI targets directly without any recording software.

**Edge recording**

The microSD card slot supports up to 2 TB of storage capacity. A microSD card can be used for local alarm recording. Pre-alarm recording in RAM reduces recording bandwidth on the network, or – if microSD card recording is used – extends the effective life of the storage medium.

**Cloud-based services**

The camera supports time-based or alarm-based JPEG posting to four different accounts. These accounts can address FTP servers or cloud-based storage facilities (for example, Dropbox). Video clips or JPEG images can also be exported to these accounts.

Alarms can be set up to trigger an e-mail or SMS notification so you are always aware of abnormal events.

**Easy installation**

Power for the camera can be supplied via a Power-over-Ethernet compliant network cable connection. With this configuration, only a single cable connection is required to view, power, and control the camera. Using PoE makes installation easier and more cost-effective, as cameras do not require a local power source.

The camera can also be supplied with power from +12 VDC power supplies.

For trouble-free network cabling, the camera supports Auto-MDIX which allows the use of straight or cross-over cables.

**True day/night switching**

The camera incorporates mechanical filter technology for vivid daytime color and exceptional night-time imaging while maintaining sharp focus under all lighting conditions.

**Hybrid mode**

An analog video output enables the camera to operate in hybrid mode. This mode provides simultaneous high resolution HD video streaming and an analog video output via an SMB connector. The hybrid functionality offers an easy migration path from legacy CCTV to a modern IP-based system.

**Access security**

Password protection with three levels and 802.1x authentication is supported. To secure Web browser access, use HTTPS with a SSL certificate stored in the camera. The video and audio communication channels can be independently AES encrypted with 128-bit keys by installing the optional encryption site license.

**Complete viewing software**

There are many ways to access the camera's features: using a web browser, with the Bosch Video Management System, with the free-of-charge Bosch Video Client or Video Security Client, with the video security mobile app, or via third-party software.

**Video security App**

The Bosch video security mobile App has been developed to enable Anywhere access to HD surveillance images allowing you to view live images from any location. The App is designed to give you complete control of all your cameras, from panning and tilting to zoom and focus functions. It's like taking your control room with you.

This App, together with the separately available Bosch transcoder, will allow you to fully utilize our dynamic transcoding features so you can play back images even over low-bandwidth connections.

**System integration**

The camera conforms to the ONVIF Profile S specification. Compliance with this standard guarantees interoperability between network video products regardless of manufacturer. Third-party integrators can easily access the internal feature set of the camera for integration into large projects. Visit the Bosch Integration Partner Program (IPP) website ([ipp.boschsecurity.com](http://ipp.boschsecurity.com)) for more information.

**Certifications and approvals**

**HD standards**

Complies with the SMPTE 274M-2008 Standard in:

- Resolution: 1920x1080
- Scan: Progressive
- Color representation: complies with ITU-R BT.709
- Aspect ratio: 16:9
- Frame rate: 25 and 30 frames/s

Complies with the SMPTE 296M-2001 Standard in:

- Resolution: 1280x720
- Scan: Progressive
- Color representation: complies with ITU-R BT.709
- Aspect ratio: 16:9
- Frame rate: 25 and 30 frames/s

Standards	IEC 62471 (IR version)
	EN 60950-1
	UL 60950-1
	UL 60950-22
	CAN/CSA-C22.2 NO. 60950-1-03
	CAN/CSA-C22.2 NO. 60950-22
	EN 50130-4
	EN 50130-5
	FCC Part 15 Subpart B, Class B
	EMC directive 2004/108/EC
	EN 55022 class B
	EN 55024
	AS/NZS CISPR 22 (equal to CISPR 22)

	ICES-003 Class B
	VCCI J55022 V2/V3
	EN 50121-4
	EN 60950-22
ONVIF compliance	EN 50132-5-2, IEC 62676-2-3
Product certifications	CE, FCC, UL, cUL, RCM, CB, VCCI
Ingress protection	IP66
Impact protection	IK10
Region	Certification
Europe	CE Outdoor 4000_5000
USA	UL Outdoor 4000_5000

**Installation/configuration notes**

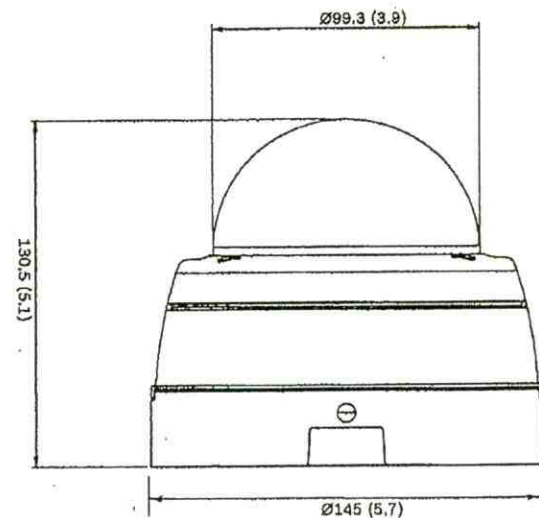

Dimensions mm (inch)

**Parts included**

- Camera
- Screw kit
- Desiccant
- Conduit adapter kit
- Installation documentation



### Technical specifications

#### Power

Input voltage	+12 VDC or Power-over-Ethernet (48 VDC nominal)
Power consumption	3.8 W max. 6.3 W max. (IR version)
PoE	IEEE 802.3af (802.3at Type 1) Power level: Class 2

#### Sensor

Sensor type	1/2.7-inch CMOS
Total sensor pixels	1952 x 1092 (2MP)

#### Video performance - Sensitivity

Sensitivity – (3200K, reflectivity 89%, F1.3, 30IRE)

Color	0.24 lx
Mono	0.05 lx
With IR	0.0 lx

#### Video performance - Dynamic range

Dynamic range	76 dB
---------------	-------

#### Video streaming

Video compression	H.264 (MP); M-JPEG
Streaming	Multiple configurable streams in H.264 and M-JPEG, configurable frame rate and bandwidth, Regions of Interest (ROI)
Overall IP Delay	Min. 120 ms, Max. 340 ms
GOP structure	IP, IBP, IBBP
Encoding Interval	1 to 25 [30] fps
Encoder regions	Eight independent areas for setting encoder quality to optimize bitrate.

#### Video resolution (H x V)

• 1080p HD	1920 X 1080
• 720p HD	1280 x 720
• D1 4:3 (cropped)	704 x 480
• SD upright (cropped)	400 x 720
• 480p SD	Encoding: 704 x 480; Displayed: 854 x 480
• 432p SD	768 x 432
• 288p SD	512 x 288
• 240p SD	Encoding: 352 x 240;

#### Video resolution (H x V)

Displayed: 432 x 240

- 144p SD 256 x 144

#### Video functions

Day/Night	Color, Monochrome, Auto
Adjustable picture settings	Contrast, Saturation, Brightness
White Balance	4 automatic modes, manual mode and measure
Shutter	Automatic Electronic Shutter (AES); Fixed (1/12 to 1/15000) selectable; Default shutter
Backlight compensation	On/off
Noise reduction	Intelligent Dynamic Noise Reduction with separate temporal and spatial adjustments
Contrast enhancement	On/off
Sharpness	Sharpness enhancement level selectable
Intelligent defog	Intelligent Defog automatically adjusts parameters for best picture in foggy or misty scenes (switchable)
Privacy Masking	Eight independent areas, fully programmable
Video Analysis	MOTION+
Other functions	Image mirror, Image flip, Pixel counter, Video watermarking, Display stamping, Scene modes, Location

#### Night vision (IR version only)

Distance	15 m (50 ft)
LED	10 LED high efficiency array, 850 nm
IR intensity	Adjustable

#### Optical

Lens type	3 to 10 mm Automatic Varifocal (AVF) lens, IR corrected DC Iris F1.3 – 3.60
Lens mount	Board mounted
Adjustment	Motorized zoom/focus
Iris control	Automatic iris control
Day/Night	Switched mechanical IR filter
Horizontal field of view	86° - 117°
Vertical field of view	20° - 61°

<b>Input/output</b>	
Analog video out	SMB connector, CVBS (PAL/NTSC), 1 Vpp, 75 Ohm
Audio line in	0.707 Vrms max, 10 kOhm typical, Jack connector
Audio line out	0.707 Vrms at 16 Ohm typical, Jack connector
Alarm input	1 Input
Alarm input activation	Short or DC 5V activation
Alarm output	1 output
Alarm output voltage	30 VDC, max. load 0.5 A
Ethernet	RJ45
<b>Audio streaming</b>	
Standard	G.711, 8 kHz sampling rate L16, 16 kHz sampling rate AAC-LC, 48 kbps at 16 kHz sampling rate AAC-LC, 80 kbps at 16 kHz sampling rate
Signal-to-Noise Ratio	>50 dB
Audio Streaming	Full-duplex / half duplex
<b>Local storage</b>	
Internal RAM	10 s pre-alarm recording
Memory card slot	Supports up to 32 GB microSDHC / 2 TB microSDXC card. (An SD card of Class 6 or higher is recommended for HD recording)
Recording	Continuous recording, ring recording, alarm/events/schedule recording
<b>Software</b>	
Unit discovery	IP Helper
Unit configuration	Via web browser or Configuration Manager
Firmware update	Remotely programmable
Software viewing	Web browser; Video Security Client; Video Security App; Bosch Video Management System; Bosch Video Client; or third party software
Latest firmware and software	<a href="http://downloadstore.boschsecurity.com/">http://downloadstore.boschsecurity.com/</a>
<b>Network</b>	
Protocols	IPv4, IPv6, UDP, TCP, HTTP, HTTPS, RTP/RTCP, IGMP V2/V3, ICMP, ICMPv6, RTSP, FTP, Telnet, ARP, DHCP, APIPA (Auto-IP; link local address), NTP (SNTP), SNMP (V1, MIB-II), 802.1x, DNS, DNSv6, DDNS

<b>Network</b>	
	(DynDNS.org, self-HOST.de, no-ip.com), SMTP, iSCSI, UPnP (SSDP), DiffServ (QoS), LLDP, SOAP, Dropbox, CHAP, digest authentication
Encryption	TLS 1.0, SSL, DES, 3DES
Ethernet	10/100 Base-T, auto-sensing, half/full duplex
Connectivity	Auto-MDIX
Interoperability	ONVIF Profile S; GB/T 28181
<b>Mechanical</b>	
3-axis adjustment (pan/tilt/rotation)	350° / 130° / 330°
Dimensions	Diameter: 145 mm (5.71 in) Height: 131 mm (5.14 in)
Weight	1102 g (2.43 lb) approx.
Color	RAL 9004, RAL 9010
<b>Environmental</b>	
Operating temperature	-30 °C to +50 °C (-22 °F to +122 °F) for continuous operation; -34 °C to +74 °C (-30 °F to +165 °F) according to NEMA TS-2-2003 (R2008), para 2.1.5.1 using fig. 2.1 test profile
Storage temperature	-30 °C to +70 °C (-22 °F to +158 °F)
Humidity	20% to 90% relative humidity (non condensing)

### Ordering information

#### FLEXIDOME IP outdoor 5000 HD

Vandal-resistant IP dome camera for outdoor HD surveillance. Automatic Varifocal 3 to 10 mm f1.3 lens; IP66; IK10; IDNR; day/night; H.264 quad-streaming; cloud services; motion/tamper/audio detection; 1080p  
Order number **NDN-50022-A3**

#### FLEXIDOME IP outdoor 5000 IR

Vandal-resistant IP dome camera for outdoor HD surveillance. Automatic Varifocal 3 to 10 mm f1.3 lens; IP66; IK10; IDNR; day/night; H.264 quad-streaming; cloud services; motion/tamper/audio detection; 1080p; Infrared  
Order number **NDI-50022-A3**

#### Accessories

##### NDA-LWMT-DOME Dome Wall Mount

Sturdy wall L-shaped bracket for dome cameras  
Order number **NDA-LWMT-DOME**

**VDA-WMT-AODOME Outdoor Wall Mount**

Sturdy outdoor wall mount bracket for dome cameras (Ø166 mm)

Order number VDA-WMT-AODOME

**VDA-PMT-AODOME Outdoor Pipe Mount**

Sturdy outdoor pipe mount bracket for dome cameras (Ø166 mm)

Order number VDA-PMT-AODOME

**LTC 9213/01 Pole Mount Adapter**

Flexible pole mount adapter for camera mounts (use together with the appropriate wall mount bracket), Max. 9 kg (20 lb); 3 to 15 inch diameter pole; stainless steel straps

Order number LTC 9213/01

**NDA-FMT-DOME In-ceiling mount**

In-ceiling flush mounting kit for dome cameras (Ø157 mm)

Order number NDA-FMT-DOME

**NDA-ADT4S-MINDOME 4S Surface Mount Box**

Surface mount box (Ø145 mm / Ø5.71 in) for dome cameras (use together with the appropriate dome adapter bracket).

Order number NDA-ADT4S-MINDOME

**Monitor/DVR Cable SMB 0.3M**

0.3 m (1 ft) analog cable, SMB (female) to BNC (female) to connect camera to coaxial cable

Order number NBN-MCSMB-03M

**Monitor/DVR Cable SMB 3.0M**

3 m (9 ft) analog cable, SMB (female) to BNC (male) to connect camera to monitor or DVR

Order number NBN-MCSMB-30M

**IP66 I/O Cable**

An IP66 certified cable for easy waterproof installation

Order number NDN-IOC-30M

Represented by:

**Americas:**  
Bosch Security Systems, Inc.  
130 Perinton Parkway  
Fairport, New York, 14450, USA  
Phone: +1 800 283 0095  
Fax: +1 585 223 9180  
security.sales@us.bosch.com  
www.boschsecurity.us

**Europe, Middle East, Africa:**  
Bosch Security Systems B.V.  
P.O. Box 80902  
5617 BA Eindhoven, The Netherlands  
Phone: +31 40 2577 284  
Fax: +31 40 2577 330  
emea.securitysystems@bosch.com  
www.boschsecurity.com

**Asia-Pacific:**  
Robert Bosch (SEA) Pte Ltd, Security  
Systems  
11 Bishan Street 21  
Singapore 573943  
Phone: +65 6671 2808  
Fax: +65 6671 2899  
apr.securitysystems@bosch.com  
www.boschsecurity.asia

**China:**  
Bosch (Shanghai) Security Systems Ltd.  
203 Building, No. 333 Fuquan Road  
North IPB  
Changning District, Shanghai  
200335 China  
Phone: +86 21 22181111  
Fax: +86 21 22182398  
www.boschsecurity.com.cn

**America Latina:**  
Robert Bosch Ltda Security Systems Division  
Via Aranguera, Km 98  
CEP 13065-900  
Campinas, Sao Paulo, Brazil  
Phone: +55 19 2103 2960  
Fax: +55 19 2103 2862  
latam.boschsecurity@bosch.com  
www.boschsecurity.com

## Cisco 200 Series Smart Switches Cisco Small Business

### Build a Powerful, Easy-to-Use Basic Business Network at an Affordable Price

The key to succeeding in today's competitive business environment is investing resources wisely – knowing how to separate the essential from the extraneous and get the most value for your dollar. As the backbone of your business and productivity applications, the small business network clearly falls into the "essential" category. But that doesn't mean you need the most advanced feature set on the market.

With Cisco® 200 Series Smart Switches, you can achieve business-class network security and performance without paying for advanced network management features that you will not need. When you need a reliable solution to share network resources and connect computers, printers, and servers, but low cost is a top priority, Cisco 200 Series Smart Switches provide the ideal solution.

Figure 1. Cisco 200 Series Smart Switches

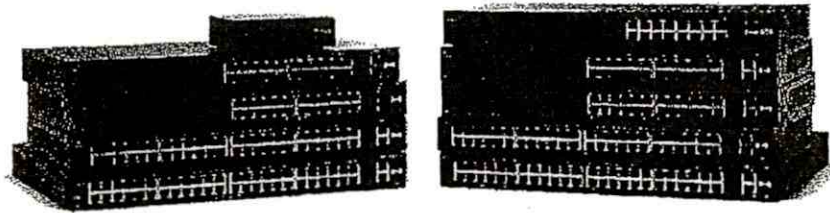

### Cisco 200 Series Smart Switches

The Cisco 200 Series (Figure 1) is a series of affordable smart switches that combine powerful network performance and reliability with the essential network management features you need for a solid business network. These expandable Fast Ethernet or Gigabit Ethernet switches provide basic management, security, and quality-of-service (QoS) features beyond those of an unmanaged or consumer-grade switch, at a lower cost than managed switches. And with an easy-to-use web user interface, Cisco Discovery Protocol, and Cisco Smartports, you can deploy and configure a rock-solid business network in minutes.

### Business Applications

Whether you need basic high-speed connectivity for your computers and servers or a comprehensive voice, data, and wireless technology solution, Cisco 200 Series switches can meet your business needs. Possible deployment scenarios include:

- **High-speed desktop connectivity.** Cisco 200 Series switches can quickly and securely connect employees working in small offices with one another and with all of the servers, printers, and other devices they use. High performance and reliable connectivity help speed file transfers and data processing, improve network uptime, and keep your employees connected and productive.

- **Highly secure wireless connectivity.** Cisco 200 Series switches work with Cisco and third-party wireless solutions to extend the reach of your network. Employees can work productively from conference rooms and common areas, collaborate in any office, and access business applications from wherever they are. With their security features, Power over Ethernet (PoE), Auto Smartports, VLAN, and QoS, these switches are the perfect foundation to add business-grade wireless to a network.
- **Unified communications.** The Cisco 200 Series provides QoS features to enable you to prioritize delay-sensitive traffic in your network and let you converge all of your communications solutions – such as IP telephony and video surveillance – onto a single Ethernet network. Cisco offers a complete portfolio of IP telephony and other unified communications products designed for small businesses, and Cisco 200 Series switches have been rigorously tested to help ensure easy integration and full compatibility with these and other vendor products.

### Features and Benefits

Cisco 200 Series Smart Switches provide all of the features you need to create a basic business-class network at an affordable price. These features include:

- **Easy configuration and management:** Cisco 200 Series switches are designed to be easy to deploy and use by small businesses or the partners that serve them. Simple-to-use web-based interfaces reduce the time it takes to deploy, manage, and troubleshoot your network. Key features include:
  - Cisco Discovery Protocol and Link Layer Discovery Protocol (LLDP-MED) automatically detect all the devices connected to your network and then automatically configure themselves for the appropriate connectivity and instruct the devices to use appropriate voice VLAN or QoS parameters.
  - Cisco Smartports technology provides for more advanced capabilities and hands-on control by automatically configuring ports with specific levels of security, QoS, and availability according to the type of connected device, based on Cisco best practices and pretested configurations. The Auto Smartports feature automatically applies the intelligence delivered through the Smartports roles to the port based on the devices discovered over Cisco Discovery Protocol or LLDP-MED. This capability facilitates zero-touch deployments.
  - Cisco FindIT Network Discovery Utility works through a simple toolbar on the user's web browser to discover Cisco devices on the network and display basic information, such as serial numbers and IP addresses, to aid in the configuration and speed the deployment of Cisco Small Business products. For more information, and to download the utility, visit [www.cisco.com/go/findit](http://www.cisco.com/go/findit).
- **Performance and reliability:** Cisco 200 Series switches have been tested to deliver the high availability and performance you would expect from a Cisco switch and help you prevent costly downtime. The switches speed file transfer times, improve slow and sluggish networks, keep your vital business applications available, and help your employees respond more quickly to customers and each other. With a network based on Cisco 200 Series switches, you can address all of your business communications and connectivity needs and reduce the total cost of ownership of your technology infrastructure.
- **Power over Ethernet (PoE):** Cisco 200 Series switches are available with PoE on both Fast Ethernet and Gigabit Ethernet models. This capability simplifies the deployment of IP telephony, wireless, video surveillance, and other solutions by allowing you to send data and power to network endpoints over the same network cable. With no need for separate power supplies or outlets for IP phones, IP cameras, or wireless access points, you can speed up deployment and installation and take advantage of advanced communications technologies quickly, and at a lower cost.

- **Network security:** Cisco 200 Series switches provide security and network management features you need to maintain a high level of security for your business, keep unauthorized users off the network, and protect your business data. The switches provide integrated network security to reduce the risk of a security breach, with IEEE 802.1X port security to control access to your network. Denial-of-service (DOS) attack prevention increases network uptime in the presence of an attack.
- **IP telephony support:** Cisco 200 Series switches include QoS features to prioritize delay-sensitive services such as voice and video, simplify unified communications deployments, and help ensure consistent network performance for all services.
- **Networkwide automatic voice deployment:** Using a combination of Cisco Discovery Protocol, LLDP-MED, Auto Smartports, and Voice Services Discovery Protocol (VSDP) – a unique patent-pending Cisco protocol – customers can deploy an end-to-end voice network dynamically. The switches in the network automatically converge into a single voice VLAN and set of QoS parameters and then propagate them out to the phones on the ports where they are discovered. For example, automated voice VLAN capabilities let you plug any IP phone (including third-party phones) into your IP telephony network and receive an immediate dial tone. The switch automatically configures the device with the right VLAN and QoS parameters to prioritize voice traffic.
- **IPv6 support:** As the IP network addressing scheme evolves to accommodate more devices, you can make sure that your network is ready. Cisco 200 Series switches provide native support for IPv6 alongside traditional IPv4. That means you can take full advantage of IPv6-enabled operating systems and applications in the future, without having to upgrade your network equipment.
- **An energy-efficient solution:** Cisco 200 Series switches are designed to be energy efficient and eco-friendly without compromising performance. They help conserve energy by optimizing power use, which helps protect the environment and lowers your energy costs. Power-saving features include:
  - Energy-Efficient Ethernet (EEE, the IEEE 802.3az standard), supported on all Cisco 200 Series Gigabit Ethernet switch models. EEE improves the efficiency of network equipment and provides standardized signaling mechanisms that can enable rapid transitions between normal operation and low power idle (LPI) states in systems on either end of the physical layer link.
  - Automatic power down on Gigabit Ethernet ports when a link is not active.
  - Embedded intelligence to adjust power based on cable length on Gigabit Ethernet models.
  - Fanless design in most models, which reduces power consumption, increases reliability, and provides quieter operation.
- **Additional Gigabit Ethernet ports:** The Cisco 200 Series provides more ports per switch than other switches in the market, giving you more flexibility to connect and empower your business. Gigabit Ethernet models feature 26- and 50-port switches, versus traditional devices that offer 20 or 44 ports with 4 shared ports. The Cisco 200 Series also offers mini Gigabit Interface Converter (mini-GBIC) expansion slots that give you the option to add fiber optic or Gigabit Ethernet uplink connectivity to the switch. With the ability to increase the connectivity range of the switches, you have more flexibility to design your network around your unique business environment, and to easily connect switches on different floors or across the business.
- **Peace of mind and investment protection:** Cisco 200 Series switches offer the reliable performance, investment protection, and peace of mind you expect from a Cisco switch. When you invest in the Cisco 200 Series, you gain the benefit of:
  - Cisco limited lifetime warranty to protect your investment.

- Rigorous testing to help ensure easy integration and compatibility with other Cisco networking and communications products, including the complete Cisco Small Business portfolio.
- **Limited lifetime warranty:** The Cisco 200 Series switches come with the Cisco Limited Lifetime Hardware Warranty, with return-to-factory replacement, a 1-year limited warranty for fans and power supplies, and a 90-day limited software warranty. In addition, Cisco offers software updates for bug fixes for the warranty term and telephone technical support at no charge for the first 12 months following the date of purchase. To download software updates, go to [www.cisco.com/cisco/web/download/index.html](http://www.cisco.com/cisco/web/download/index.html).
- **World-class support:** To extend the support coverage beyond the warranty provisions, choose the Cisco Small Business Support Service, which helps you get the most value from Cisco Small Business solutions, providing peace of mind at an affordable price. The subscription-based service offers software upgrades and updates, access to the Cisco Small Business Support Center, next-business-day hardware replacement (if needed), and telephone and online chat support. To learn more, visit [www.cisco.com/go/smbservices](http://www.cisco.com/go/smbservices).  
To find out where Cisco Small Business Support Service is available by country, go to <https://supportforums.cisco.com/community/netpro/small-business/sbcountrysupport>.
- Multiple language options: The Cisco 200 Series is available in seven languages: English, French, German, Italian, Spanish, Japanese, and simplified Chinese. All product documentation and most user interfaces are translated, giving you the ability to select your preferred language.

## Product Specifications

Table 1 gives the product specifications for the Cisco 200 Series Switches.

Table 1. Product Specifications

Feature	Description		
<b>Performance</b>			
Switching capacity and forwarding rate	Model		
	SF200-24	Capacity in Millions of Packets per Second (mppps) (64-byte packets)	Switching Capacity in Gigabits per Second (Gbps)
	SF200-24P	6.55	8.8
	SF200-24FP	6.55	8.8
	SF200-48	6.55	8.8
	SF200-48P	10.12	13.6
	SG200-08	10.12	13.6
	SG200-08P	11.9	13.6
	SG200-08FP	11.9	13.6
	SG200-10FP	14.88	20.0
	SG200-18	26.78	36.0
	SG200-26	38.89	52.0
	SG200-26P	38.89	52.0
	SG200-26FP	38.89	52.0
SG200-50	74.41	100.0	
SG200-50P	74.41	100.0	
SG200-50FP	74.41	100.0	
<b>Layer 2 Switching</b>			
Spanning Tree Protocol (STP)	Standard 802.1d STP support		
	Fast convergence using 802.1w (Rapid Spanning Tree [RSTP]), enabled by default		

Feature	Description
Port grouping	Support for IEEE 802.3ad Link Aggregation Control Protocol (LACP) <ul style="list-style-type: none"> <li>Up to 4 groups</li> <li>Up to 8 ports per group with 16 candidate ports for each (dynamic) 802.3ad link aggregation</li> </ul>
VLAN	Support for up to 256 VLANs simultaneously (out of 4096 VLAN IDs). 16 VLANs supported in SG200-08 and SG200-08P Port-based and 802.1Q tag-based VLANs
Voice VLAN	Voice traffic is automatically assigned to a voice-specific VLAN and treated with appropriate levels of QoS
Internet Group Management Protocol (IGMP) versions 1 and 2 snooping	IGMP limits bandwidth-intensive multicast traffic to only the requesters; supports 256 multicast groups
Head-of-Line (HOL) blocking	HOL blocking prevention
<b>Security</b>	
IEEE 802.1X (Authenticator role)	802.1X: RADIUS authentication, MD5 hash
Port security	Locks MAC addresses to ports, and limits the number of learned MAC addresses
Storm control	Broadcast, multicast, and unknown unicast
DoS prevention	DoS attack prevention
<b>Quality of Service</b>	
Priority levels	4 hardware queues
Scheduling	Strict priority and weighted round-robin (WRR) Queue assignment based on differentiated services code point (DSCP) and class of service (802.1p/CoS)
Class of service	Port based, 802.1p VLAN priority based, IPv4/v6 IP precedence/type of service (ToS)/DSCP based, Differentiated Services (DiffServ)
Rate limiting	Ingress policer, per VLAN and per port
<b>Standards</b>	
Standards	IEEE 802.3 10BASE-T Ethernet, IEEE 802.3u 100BASE-TX Fast Ethernet, IEEE 802.3ab 1000BASE-T Gigabit Ethernet, IEEE 802.3ad LACP, IEEE 802.3z Gigabit Ethernet, IEEE 802.3x Flow Control, IEEE 802.1D (STP), IEEE 802.1Q/p VLAN, IEEE 802.1w RSTP, IEEE 802.1X Port Access Authentication, IEEE 802.3af, RFC 708, RFC 783, RFC 791, RFC 792, RFC 793, RFC 813, RFC 879, RFC 898, RFC 828, RFC 854, RFC 856, RFC 858, RFC 858, RFC 894, RFC 819, RFC 922, RFC 920, RFC 980, RFC 961, RFC 1042, RFC 1071, RFC 1123, RFC 1141, RFC 1155, RFC 1350, RFC 1533, RFC 1541, RFC 1542, RFC 1624, RFC 1700, RFC 1867, RFC 2030, RFC 2616, RFC 2131, RFC 2132, RFC 3164, RFC 2818
<b>IPv6</b>	
IPv6	IPv6 host mode IPv6 over Ethernet Dual IPv6/IPv4 stack IPv6 neighbor and router discovery (ND) IPv6 stateless address auto-configuration Path maximum transmission unit (MTU) discovery Duplicate address detection (DAD) Internet Control Message Protocol (ICMP) version 6 IPv6 over IPv4 network with Intra-Site Automatic Tunnel Addressing Protocol (ISATAP) support
IPv6 QoS	Prioritize IPv6 packets in hardware
Multicast Listener Discovery (MLD) snooping	Deliver IPv6 multicast packets only to the required receivers
IPv6 applications	Web, ping, Simple Network Time Protocol (SNTP), Trivial File Transfer Protocol (TFTP), RADIUS, syslog, DNS client



Feature	Description																																																												
IPv6 RFCs supported	<p>RFC 2463: ICMP version 6</p> <p>RFC 3513: IPv6 address architecture</p> <p>RFC 4291: IPv6 addressing architecture</p> <p>RFC 2460: IPv6 specification</p> <p>RFC 2461: Neighbor discovery for IPv6</p> <p>RFC 2462: IPv6 stateless address auto-configuration</p> <p>RFC 1981: Path maximum transmission unit (MTU) discovery</p> <p>RFC 4007: IPv6 scoped address architecture</p> <p>RFC 3484: Default address selection mechanism</p> <p>RFC 4214: ISATAP tunneling</p> <p>RFC 4293: MIB IPv6: Textual conventions and general group</p> <p>RFC 3595: Textual conventions for IPv6 flow label</p>																																																												
<b>Management</b>																																																													
Web user interface	Built-in switch configuration utility for easy browser-based device configuration (HTTP). Supports configuration, system dashboard, system maintenance, and monitoring																																																												
Simple Network Management Protocol (SNMP)	SNMP versions 1, 2c, and 3 with support for traps, and SNMP version 3 user-based security model (USM)																																																												
Standard MIBs	<table border="0"> <tr> <td>draft-ietf-bridge-8021x-MIB</td> <td>rfc2011-MIB</td> </tr> <tr> <td>draft-ietf-bridge-relpmib-04-MIB</td> <td>draft-ietf-entmib-sensor-MIB</td> </tr> <tr> <td>draft-ietf-hubmib-etherif-MIB-v3-00-MIB</td> <td>lldp-MIB</td> </tr> <tr> <td>draft-ietf-syslog-device-MIB</td> <td>lldpextdot1-MIB</td> </tr> <tr> <td>ianaaddrfamnumbers-MIB</td> <td>lldpextdot3-MIB</td> </tr> <tr> <td>ianaafly-MIB</td> <td>lldpextmed-MIB</td> </tr> <tr> <td>ianaprot-MIB</td> <td>p-bridge-MIB</td> </tr> <tr> <td>inet-address-MIB</td> <td>q-bridge-MIB</td> </tr> <tr> <td>ip-forward-MIB</td> <td>rfc1388-MIB</td> </tr> <tr> <td>ip-MIB</td> <td>rfc1493-MIB</td> </tr> <tr> <td>RFC1155-SMI</td> <td>rfc1611-MIB</td> </tr> <tr> <td>RFC1213-MIB</td> <td>rfc1612-MIB</td> </tr> <tr> <td>SNMPv2-MIB</td> <td>rfc1850-MIB</td> </tr> <tr> <td>SNMPv2-SMI</td> <td>rfc1907-MIB</td> </tr> <tr> <td>SNMPv2-TM</td> <td>rfc2571-MIB</td> </tr> <tr> <td>RMON-MIB.my</td> <td>rfc2572-MIB</td> </tr> <tr> <td>dcb-rej-DCBX-MIB-1108-MIB</td> <td>rfc2574-MIB</td> </tr> <tr> <td>rfc1724-MIB</td> <td>rfc2576-MIB</td> </tr> <tr> <td>RFC-1212.my_for_MG-Soft</td> <td>rfc2613-MIB</td> </tr> <tr> <td>rfc1213-MIB</td> <td>rfc2665-MIB</td> </tr> <tr> <td>rfc1757-MIB</td> <td>rfc2868-MIB</td> </tr> <tr> <td>RFC-1215.my</td> <td>rfc2737-MIB</td> </tr> <tr> <td>SNMPv2-CONF.my</td> <td>rfc2925-MIB</td> </tr> <tr> <td>SNMPv2-TC.my</td> <td>rfc3021-MIB</td> </tr> <tr> <td>rfc2674-MIB</td> <td>rfc4668-MIB</td> </tr> <tr> <td>rfc2575-MIB</td> <td>rfc4670-MIB</td> </tr> <tr> <td>rfc2573-MIB</td> <td>trunk-MIB</td> </tr> <tr> <td>rfc2233-MIB</td> <td>tunnel-MIB</td> </tr> <tr> <td>rfc2013-MIB</td> <td>udp-MIB</td> </tr> <tr> <td>rfc2012-MIB</td> <td></td> </tr> </table>	draft-ietf-bridge-8021x-MIB	rfc2011-MIB	draft-ietf-bridge-relpmib-04-MIB	draft-ietf-entmib-sensor-MIB	draft-ietf-hubmib-etherif-MIB-v3-00-MIB	lldp-MIB	draft-ietf-syslog-device-MIB	lldpextdot1-MIB	ianaaddrfamnumbers-MIB	lldpextdot3-MIB	ianaafly-MIB	lldpextmed-MIB	ianaprot-MIB	p-bridge-MIB	inet-address-MIB	q-bridge-MIB	ip-forward-MIB	rfc1388-MIB	ip-MIB	rfc1493-MIB	RFC1155-SMI	rfc1611-MIB	RFC1213-MIB	rfc1612-MIB	SNMPv2-MIB	rfc1850-MIB	SNMPv2-SMI	rfc1907-MIB	SNMPv2-TM	rfc2571-MIB	RMON-MIB.my	rfc2572-MIB	dcb-rej-DCBX-MIB-1108-MIB	rfc2574-MIB	rfc1724-MIB	rfc2576-MIB	RFC-1212.my_for_MG-Soft	rfc2613-MIB	rfc1213-MIB	rfc2665-MIB	rfc1757-MIB	rfc2868-MIB	RFC-1215.my	rfc2737-MIB	SNMPv2-CONF.my	rfc2925-MIB	SNMPv2-TC.my	rfc3021-MIB	rfc2674-MIB	rfc4668-MIB	rfc2575-MIB	rfc4670-MIB	rfc2573-MIB	trunk-MIB	rfc2233-MIB	tunnel-MIB	rfc2013-MIB	udp-MIB	rfc2012-MIB	
draft-ietf-bridge-8021x-MIB	rfc2011-MIB																																																												
draft-ietf-bridge-relpmib-04-MIB	draft-ietf-entmib-sensor-MIB																																																												
draft-ietf-hubmib-etherif-MIB-v3-00-MIB	lldp-MIB																																																												
draft-ietf-syslog-device-MIB	lldpextdot1-MIB																																																												
ianaaddrfamnumbers-MIB	lldpextdot3-MIB																																																												
ianaafly-MIB	lldpextmed-MIB																																																												
ianaprot-MIB	p-bridge-MIB																																																												
inet-address-MIB	q-bridge-MIB																																																												
ip-forward-MIB	rfc1388-MIB																																																												
ip-MIB	rfc1493-MIB																																																												
RFC1155-SMI	rfc1611-MIB																																																												
RFC1213-MIB	rfc1612-MIB																																																												
SNMPv2-MIB	rfc1850-MIB																																																												
SNMPv2-SMI	rfc1907-MIB																																																												
SNMPv2-TM	rfc2571-MIB																																																												
RMON-MIB.my	rfc2572-MIB																																																												
dcb-rej-DCBX-MIB-1108-MIB	rfc2574-MIB																																																												
rfc1724-MIB	rfc2576-MIB																																																												
RFC-1212.my_for_MG-Soft	rfc2613-MIB																																																												
rfc1213-MIB	rfc2665-MIB																																																												
rfc1757-MIB	rfc2868-MIB																																																												
RFC-1215.my	rfc2737-MIB																																																												
SNMPv2-CONF.my	rfc2925-MIB																																																												
SNMPv2-TC.my	rfc3021-MIB																																																												
rfc2674-MIB	rfc4668-MIB																																																												
rfc2575-MIB	rfc4670-MIB																																																												
rfc2573-MIB	trunk-MIB																																																												
rfc2233-MIB	tunnel-MIB																																																												
rfc2013-MIB	udp-MIB																																																												
rfc2012-MIB																																																													

Feature	Description
Private MIBs	<p>CISCOB-ldp-MIB</p> <p>CISCOB-brgmulticast-MIB</p> <p>CISCOB-bridgemibobjects-MIB</p> <p>CISCOB-bonjour-MIB</p> <p>CISCOB-dhcpd-MIB</p> <p>CISCOB-MIB</p> <p>CISCOB-wrandomlaldrop-MIB</p> <p>CISCOB-traceroute-MIB</p> <p>CISCOB-letnet-MIB</p> <p>CISCOB-stormctrl-MIB</p> <p>CISCOB-ssh-MIB</p> <p>CISCOB-socket-MIB</p> <p>CISCOB-sntp-MIB</p> <p>CISCOB-smon-MIB</p> <p>CISCOB-phy-MIB</p> <p>CISCOB-mullisessionterminal-MIB</p> <p>CISCOB-rrt-MIB</p> <p>CISCOB-jumboframes-MIB</p> <p>CISCOB-gvrp-MIB</p> <p>CISCOB-endofmib-MIB</p> <p>CISCOB-dot1x-MIB</p> <p>CISCOB-deviceparams-MIB</p> <p>CISCOB-clf-MIB</p> <p>CISCOB-cdb-MIB</p> <p>CISCOB-brgmacswitch-MIB</p> <p>CISCOB-3sw2swtables-MIB</p> <p>CISCOB-smartPorts-MIB</p> <p>CISCOB-tbl-MIB</p> <p>CISCOB-mecbaseprio-MIB</p> <p>CISCOB-policy-MIB</p> <p>CISCOB-env_mib</p> <p>CISCOB-sensor-MIB</p> <p>CISCOB-aaa-MIB</p> <p>CISCOB-application-MIB</p> <p>CISCOB-bridgesecurity-MIB</p> <p>CISCOB-copy-MIB</p> <p>CISCOB-CpuCounters-MIB</p> <p>CISCOB-Custom1BonjourService-MIB</p> <p>CISCOB-dhcp-MIB</p> <p>CISCOB-clf-MIB</p> <p>CISCOB-dnscl-MIB</p> <p>CISCOB-embweb-MIB</p> <p>CISCOB-fft-MIB</p> <p>CISCOB-file-MIB</p> <p>CISCOB-greeneth-MIB</p> <p>CISCOB-Interfaces-MIB</p> <p>CISCOB-Interfaces_recovery-MIB</p> <p>CISCOB-IP-MIB</p> <p>CISCOB-iprovider-MIB</p> <p>CISCOB-ipv6-MIB</p> <p>CISCOB-mnginf-MIB</p> <p>CISCOB-ldl-MIB</p> <p>CISCOB-localization-MIB</p> <p>CISCOB-momngr-MIB</p> <p>CISCOB-mng-MIB</p> <p>CISCOB-physdescription-MIB</p> <p>CISCOB-Poe-MIB</p> <p>CISCOB-protectedport-MIB</p> <p>CISCOB-rmon-MIB</p> <p>CISCOB-rs232-MIB</p> <p>CISCOB-SecuritySuite-MIB</p> <p>CISCOB-srmp-MIB</p> <p>CISCOB-specialb pdu-MIB</p> <p>CISCOB-banner-MIB</p> <p>CISCOB-syslog-MIB</p> <p>CISCOB-TopSession-MIB</p> <p>CISCOB-traps-MIB</p> <p>CISCOB-trunk-MIB</p> <p>CISCOB-tuning-MIB</p> <p>CISCOB-tunnel-MIB</p> <p>CISCOB-udp-MIB</p> <p>CISCOB-vlan-MIB</p> <p>CISCOB-ipsdact-MIB</p> <p>CISCO-SMI-MIB</p> <p>CISCO-DebugCapabilities-MIB</p> <p>CISCOB-CDP-MIB</p> <p>CISCOB-vlanVoice-MIB</p> <p>CISCOB-EVENTS-MIB</p> <p>CISCOB-sysmng-MIB</p> <p>CISCOB-scl-MIB</p> <p>CISCO-TC-MIB</p> <p>CISCO-VTP-MIB</p> <p>CISCO-CDP-MIB</p> <p>CISCOB-eee-MIB</p> <p>CISCOB-ssl-MIB</p> <p>CISCOB-qosclmib-MIB</p> <p>CISCOB-digitalkeymanage-MIB</p> <p>CISCOB-tbp-MIB</p> <p>CISCOB-MIB</p> <p>CISCOB-secad-MIB</p> <p>CISCOB-draft-ietf-entmib-sensor-MIB</p> <p>CISCOB-draft-ietf-eyek-devic-MIB</p> <p>CISCOB-ric2925-MIB</p>
Remote Monitoring (RMON)	Embedded RMON software agent supports 4 RMON groups (history, statistics, alarms, and events) for enhanced traffic management, monitoring, and analysis
IPv4 and IPv6 dual stack	Coexistence of both protocol stacks to ease migration
Firmware upgrade	Web browser upgrade (HTTP) and TFTP
Port mirroring	Traffic on a port can be mirrored to another port for analysis with a network analyzer or RMON probe. Up to 4 source ports can be mirrored to one destination port. A single session is supported.
VLAN mirroring	Traffic from a VLAN can be mirrored to a port for analysis with a network analyzer or RMON probe. Up to 4 source VLANs can be mirrored to one destination port. A single session is supported.

Feature	Description																														
Dynamic Host Configuration Protocol (DHCP) (options 66 and 67)	(DHCP) options facilitate tighter control from a central point (DHCP server) to obtain IP address and perform auto-configuration (with configuration file download)																														
Text-editable config files	Config files can be edited with a text editor and downloaded to another switch, facilitating easier mass deployment																														
Smartports	Simplified configuration of QoS and security capabilities																														
Auto Smartports	Automatically applies the intelligence delivered through the Smartports roles to the port based on the devices discovered over Cisco Discovery Protocol or LLDP-MED. This facilitates zero touch deployments.																														
Cloud services	Support for FindIT Network Discovery Utility and Cisco OnPlus™ technology																														
Localization	Localization of GUI and documentation into multiple languages																														
Other management	HTTP, RADIUS, port mirroring, TFTP upgrade, DHCP client, BOOTP, SNMP, ping, syslog																														
<b>Power Efficiency</b>																															
EEE compliant (802.3az)	Supports 802.3az on all copper Gigabit Ethernet ports (SG200-xx models) Not supported on SG200-08 and SG200-08P models																														
Energy Detect mode	Automatically turns off power on Gigabit Ethernet RJ-45 port when the switch detects a link down Active mode is resumed without loss of any packets when the switch detects that the link is back up																														
Cable length detection	Adjusts the signal strength based on the cable length. Reduces the power consumption for cables shorter than 10 m.																														
<b>General</b>																															
Jumbo frames	Frame sizes up to 10 KB supported on 10/100 and Gigabit Ethernet interfaces (9 KB for SG200-08 and SG200-08P)																														
MAC table	Up to 8000 MAC addresses																														
<b>Discovery</b>																															
Link Layer Discovery Protocol (LLDP) (802.1ab) with LLDP-MED extensions	LLDP allows the switch to advertise its identification, configuration, and capabilities to neighboring devices, which store the data in an MIB. LLDP-MED is an enhancement to LLDP that adds the extensions needed for IP phones.																														
Cisco Discovery Protocol	The switch advertises itself using the Cisco Discovery Protocol. It also learns the connected device and its characteristics via this protocol.																														
Auto Smartports	Automatically applies the intelligence delivered through the Smartports roles to the port based on the devices discovered over Cisco Discovery Protocol or LLDP-MED. This capability facilitates zero-touch deployments.																														
Bonjour	The switch advertises itself using the Bonjour protocol																														
<b>Power over Ethernet (PoE)</b>																															
IEEE 802.3af PoE delivered on half of the RJ-45 ports within the listed power budgets	Maximum power of 15.4W to any 10/100 or Gigabit Ethernet base port supporting PoE. The total power available for PoE per switch is as follows:																														
	<table border="1"> <thead> <tr> <th>Model</th> <th>Power Dedicated to PoE</th> <th>Number of Ports That Support PoE</th> </tr> </thead> <tbody> <tr> <td>SF200-24P</td> <td>100W</td> <td>12</td> </tr> <tr> <td>SF200-24FP</td> <td>180W</td> <td>24</td> </tr> <tr> <td>SF200-48P</td> <td>180W</td> <td>24</td> </tr> <tr> <td>SG200-08P</td> <td>32W</td> <td>4</td> </tr> <tr> <td>SG200-10FP</td> <td>62W</td> <td>8</td> </tr> <tr> <td>SG200-26P</td> <td>100W</td> <td>12</td> </tr> <tr> <td>SG200-26FP</td> <td>180W</td> <td>24</td> </tr> <tr> <td>SG200-50P</td> <td>180W</td> <td>24</td> </tr> <tr> <td>SG200-50FP</td> <td>375W</td> <td>48</td> </tr> </tbody> </table>	Model	Power Dedicated to PoE	Number of Ports That Support PoE	SF200-24P	100W	12	SF200-24FP	180W	24	SF200-48P	180W	24	SG200-08P	32W	4	SG200-10FP	62W	8	SG200-26P	100W	12	SG200-26FP	180W	24	SG200-50P	180W	24	SG200-50FP	375W	48
Model	Power Dedicated to PoE	Number of Ports That Support PoE																													
SF200-24P	100W	12																													
SF200-24FP	180W	24																													
SF200-48P	180W	24																													
SG200-08P	32W	4																													
SG200-10FP	62W	8																													
SG200-26P	100W	12																													
SG200-26FP	180W	24																													
SG200-50P	180W	24																													
SG200-50FP	375W	48																													
Power consumption	<table border="1"> <thead> <tr> <th>Model</th> <th>Power Savings Mode</th> <th>Power Consumption: Worst Case</th> <th>Heat Dissipation (BTU/hr)</th> </tr> </thead> <tbody> <tr> <td>SF200-24</td> <td>Energy Detect</td> <td>110V/0.272A/13.7 W 220V/0.169A/14.5 W</td> <td>49.5</td> </tr> </tbody> </table>	Model	Power Savings Mode	Power Consumption: Worst Case	Heat Dissipation (BTU/hr)	SF200-24	Energy Detect	110V/0.272A/13.7 W 220V/0.169A/14.5 W	49.5																						
Model	Power Savings Mode	Power Consumption: Worst Case	Heat Dissipation (BTU/hr)																												
SF200-24	Energy Detect	110V/0.272A/13.7 W 220V/0.169A/14.5 W	49.5																												

Feature	Description			
	SF200-24P	Energy Detect	110V/0.346A/21.3 W 220V/0.166A/22.2 W	75.8
	SF200-24FP	Short reach plus Energy Detect	110V/0.231A/23.5 W 220V/0.179A/24.4 W	85.8
	SF200-48	Energy Detect	110V/0.453A/26.2 W 220V/0.276A/28.8 W	91.5
	SF200-48P	Energy Detect	110V/0.355A/37.2 W 220V/0.217A/37.4 W	127.8
	SG200-08	Auto power down for link down	110V/P=6.7W 220V/P=7.21W	24.8
	SG200-08P	Auto power down for link down	110V/P=7.6W 220V/P=8.1W	27.8
	SG200-10FP	Short reach plus Energy Detect	110V/P=13.13W 220V/P=13.48W	46.0
	SG200-18	Energy Detect (link down), short reach	110V/P=22.4W 220V/P=22.9W	78.2
	SG200-26	Short reach plus Energy Detect	110V/0.513A/27.8 W 220V/0.306A/28.3 W	98.8
	SG200-26P	Short reach plus Energy Detect	110V/0.691A/36.8 W 220V/0.381A/37.5 W	97.9
	SG200-26FP	Short reach plus Energy Detect	110V/0.269A/27.8 W 220V/0.196A/28.7 W	128.0
	SG200-50	Short reach plus Energy Detect	110V/0.559A/61.8 W 220V/0.296A/61.4 W	209.6
	SG200-50P	Short reach plus Energy Detect	110V/0.595A/62W 220V/0.338A/61.2 W	211.6
	SG200-50FP	Short reach plus Energy Detect	110V/0.749A/78.4 W 220V/0.412A/78.3 W	267.2
Ports	Model Name	Total System Ports	RJ-45 Ports	Combo Ports (RJ-45 + SFP)
	SF200-24	24 Fast Ethernet 2 Gigabit Ethernet	24 Fast Ethernet	2 Gigabit Ethernet combo
	SF200-24P	24 Fast Ethernet 2 Gigabit Ethernet	24 Fast Ethernet	2 Gigabit Ethernet combo
	SF200-24FP	24 Fast Ethernet 2 Gigabit Ethernet	24 Fast Ethernet	2 Gigabit Ethernet combo
	SF200-48	48 Fast Ethernet 2 Gigabit Ethernet	48 Fast Ethernet	2 Gigabit Ethernet combo
	SF200-48P	48 Fast Ethernet 2 Gigabit Ethernet	48 Fast Ethernet	2 Gigabit Ethernet combo
	SG200-08	8 Gigabit Ethernet	8 Gigabit Ethernet	-

Feature	Description			
	SG200-08P	8 Gigabit Ethernet	8 Gigabit Ethernet	--
	SG200-10FP	8 Gigabit Ethernet	8 Gigabit Ethernet	2 Gigabit Ethernet combo
	SG200-18	16 Gigabit Ethernet	16 Gigabit Ethernet	2 Gigabit Ethernet combo
	SG200-26	26 Gigabit Ethernet	24 Gigabit Ethernet	2 Gigabit Ethernet combo
	SG200-26P	26 Gigabit Ethernet	24 Gigabit Ethernet	2 Gigabit Ethernet combo
	SG200-26FP	26 Gigabit Ethernet	24 Gigabit Ethernet	2 Gigabit Ethernet combo
	SG200-50	50 Gigabit Ethernet	48 Gigabit Ethernet	2 Gigabit Ethernet combo
	SG200-50P	50 Gigabit Ethernet	48 Gigabit Ethernet	2 Gigabit Ethernet combo
	SG200-50FP	50 Gigabit Ethernet	48 Gigabit Ethernet	2 Gigabit Ethernet combo
Buttons	Reset button			
Cabling type	Unshielded twisted pair (UTP) Category 5 or better for 10BASE-T/100BASE-TX; UTP Category 5 Ethernet or better for 1000BASE-T			
LEDs	System, Link/Act, PoE, Speed			
Flash	16 MB (8 MB in SG200-08 and SG200-08P)			
CPU memory	128 MB (32 MB in SG200-08 and SG200-08P)			
Packet buffer	All numbers are aggregates across all ports, as the buffers are dynamically shared:			
	<b>Model</b>			<b>Packet Buffer</b>
	SF200-24			4 Mb
	SF200-24P			4 Mb
	SF200-24FP			4 Mb
	SF200-48			2 @ 8 Mb
	SF200-48P			2 @ 8 Mb
	SG200-08			4 Mb
	SG200-08P			4 Mb
	SG200-10FP			4 Mb
	SG200-18			4 Mb
	SG200-26			4 Mb
	SG200-26P			4 Mb
	SG200-26FP			4 Mb
	SG200-50			2 @ 8 Mb
	SG200-50P			2 @ 8 Mb
	SG200-50FP			2 @ 8 Mb
Supported Small Form-Factor Pluggable (SFP) Modules	<b>Product Ordering Number</b>	<b>Media</b>	<b>Speed</b>	<b>Typical Distance</b>
	MFEFX1	Multimode fiber	100 Mbps	2 km
	MFELX1	Single-mode fiber	100 Mbps	10 km
	MFEBX1	Single-mode fiber	100 Mbps	20 km
	MGBBX1	Single-mode fiber	1000 Mbps	40 km
	MGBSX1	Multimode fiber	1000 Mbps	300 m
	MGBLH1	Single-mode fiber	1000 Mbps	40 km
	MGBLX1	Single-mode fiber	1000 Mbps	10 km

Feature	Description		
<b>Environmental</b>			
Dimensions (W x H x D)	Model	Metric (mm)	Inches
	SF200-24	440 x 44.32 x 257	17.35 x 1.74 x 10.1
	SF200-24P	440 x 44 x 257	17.35 x 1.73 x 10.1
	SF200-24FP	440 x 44 x 257	17.35 x 1.73 x 10.1
	SF200-48	440 x 44 x 257	17.35 x 1.73 x 10.1
	SF200-48P	440 x 44.32 x 350	17.35 x 1.74 x 13.8
	SG200-08	113 x 27 x 130	4.45 x 1.06 x 5.12
	SG200-08P	130 x 42.3 x 130	6.12 x 1.52 x 6.12
	SG200-10FP	279.4 x 44.45 x 170	11 x 1.45 x 6.7
	SG200-18	440.6 x 44.32 x 202.82	17.35 x 1.74 x 7.99
	SG200-26	440 x 44 x 257	17.35 x 1.73 x 10.1
	SG200-26P	440 x 44 x 257	17.35 x 1.73 x 10.1
	SG200-26FP	440 x 44 x 257	17.35 x 1.73 x 10.1
	SG200-50	440 x 44 x 257	17.35 x 1.73 x 10.1
	SG200-50P	440 x 44 x 350	17.35 x 1.73 x 13.8
	SG200-50FP	440 x 44 x 350	17.35 x 1.73 x 13.8
	Unit weight	Model	Kilograms
SF200-24		3.04	6.70
SF200-24P		3.45	7.61
SF200-24FP		3.67	8.09
SF200-48		3.42	7.54
SF200-48P		4.73	10.43
SG200-08		0.75	1.65
SG200-08P		1.26	2.78
SG200-10FP		1.26	2.78
SG200-18		2.01	4.43
SG200-26		3.27	7.21
SG200-26P		3.67	8.09
SG200-26FP		3.82	8.42
SG200-50		3.96	8.73
SG200-50P		5.47	12.06
SG200-50FP		6.04	13.32
Power		Model	Power
	SF200-24	100V-240V, 12V/2.5A, 50-60 HZ	
	SF200-24P	100V-240V, 50V/2A, 50-60 HZ	
	SF200-24FP	100V-240V 47-63 Hz, Internal, universal 100V-240V, 50V/3.6A, 12V/4, 50-60 Hz	
	SF200-48	100V-240V, 12V/4.5A, 60-60 HZ	
	SF200-48P	100V-240V, 50V/3.6A, 12V/4A, 50-60 HZ	
	SG200-08	(external) 100V-240V, 0.6A, 50-60 HZ	
	SG200-08P	(external) 100V-240V, 1.0.66A, 50-60 HZ	
	SG200-10FP	(external) 100V-240V, 2.5A, 50-60 Hz	

Feature	Description																																																																
	<table border="0"> <tr> <td>SG200-18</td> <td>100V-240V, 1.0-0.5A, 50-60 HZ</td> </tr> <tr> <td>SG200-28</td> <td>100V-240V, 12V/2.5A, 50-60 HZ</td> </tr> <tr> <td>SG200-28P</td> <td>100V-240V, 60V/2A, 50-60 HZ</td> </tr> <tr> <td>SG200-28FP</td> <td>100V-240V 50-60 Hz, internal, universal</td> </tr> <tr> <td></td> <td>100V-240V, 50V/3.6A, 12V/4, 50-60 Hz</td> </tr> <tr> <td>SG200-50</td> <td>110V-240V, 12V/8.33A, 50-60 HZ</td> </tr> <tr> <td>SG200-50P</td> <td>100V-240V, 50V/2A, 50-60 HZ</td> </tr> <tr> <td>SG200-50FP</td> <td>100V-240V 47-63 Hz, internal, universal</td> </tr> <tr> <td></td> <td>100V-240V, 50V/7.5A, 12V/7.5A, 50-60 Hz</td> </tr> </table>	SG200-18	100V-240V, 1.0-0.5A, 50-60 HZ	SG200-28	100V-240V, 12V/2.5A, 50-60 HZ	SG200-28P	100V-240V, 60V/2A, 50-60 HZ	SG200-28FP	100V-240V 50-60 Hz, internal, universal		100V-240V, 50V/3.6A, 12V/4, 50-60 Hz	SG200-50	110V-240V, 12V/8.33A, 50-60 HZ	SG200-50P	100V-240V, 50V/2A, 50-60 HZ	SG200-50FP	100V-240V 47-63 Hz, internal, universal		100V-240V, 50V/7.5A, 12V/7.5A, 50-60 Hz																																														
SG200-18	100V-240V, 1.0-0.5A, 50-60 HZ																																																																
SG200-28	100V-240V, 12V/2.5A, 50-60 HZ																																																																
SG200-28P	100V-240V, 60V/2A, 50-60 HZ																																																																
SG200-28FP	100V-240V 50-60 Hz, internal, universal																																																																
	100V-240V, 50V/3.6A, 12V/4, 50-60 Hz																																																																
SG200-50	110V-240V, 12V/8.33A, 50-60 HZ																																																																
SG200-50P	100V-240V, 50V/2A, 50-60 HZ																																																																
SG200-50FP	100V-240V 47-63 Hz, internal, universal																																																																
	100V-240V, 50V/7.5A, 12V/7.5A, 50-60 Hz																																																																
Certification	UL (UL 60950), CSA (CSA 22.2), CE mark, FCC Part 15 (CFR 47) Class A																																																																
Operating temperature	32° to 104°F (0° to 40°C)																																																																
Storage temperature	-4° to 158°F (-20° to 70°C)																																																																
Operating humidity	10% to 90%, relative, noncondensing																																																																
Storage humidity	10% to 90%, relative, noncondensing																																																																
Acoustic noise and mean time between failures (MTBF)	<table border="1"> <thead> <tr> <th>Model</th> <th>Fan (Number)</th> <th>Acoustic Noise</th> <th>MTBF @ 40°C (hours)</th> </tr> </thead> <tbody> <tr> <td>SF200-24</td> <td>No</td> <td>N/A</td> <td>414,166</td> </tr> <tr> <td>SF200-24P</td> <td>1</td> <td>40.2 dB</td> <td>307,098</td> </tr> <tr> <td>SF200-24FP</td> <td>2</td> <td>40.2 dB at 45°C</td> <td>314,444.5 (based on 45°C)</td> </tr> <tr> <td>SF200-48</td> <td>No</td> <td>-</td> <td>267,865</td> </tr> <tr> <td>SF200-48P</td> <td>2</td> <td>41.7 dB</td> <td>174,966</td> </tr> <tr> <td>SG200-08</td> <td>No</td> <td>-</td> <td>71,834</td> </tr> <tr> <td>SG200-10FP</td> <td>No</td> <td>-</td> <td>287,436 (based on 45°C)</td> </tr> <tr> <td>SG200-08P</td> <td>No</td> <td>-</td> <td>69,003</td> </tr> <tr> <td>SG200-16</td> <td>No</td> <td>-</td> <td>68,033</td> </tr> <tr> <td>SG200-28</td> <td>No</td> <td>-</td> <td>194,278</td> </tr> <tr> <td>SG200-28P</td> <td>1</td> <td>40.2 dB</td> <td>218,842</td> </tr> <tr> <td>SG200-28FP</td> <td>2</td> <td>40.2 dB at 45°C</td> <td>319,407 (based on 45°C)</td> </tr> <tr> <td>SG200-50</td> <td>2</td> <td>41.7 dB</td> <td>237,810</td> </tr> <tr> <td>SG200-50P</td> <td>4</td> <td>42.5 dB at 30°C 54.7 dB at 40°C</td> <td>208,978</td> </tr> <tr> <td>SG200-50FP</td> <td>4</td> <td>42.1 dB at 30°C 55.9 dB at 50°C</td> <td>192,790 (based on 45°C)</td> </tr> </tbody> </table>	Model	Fan (Number)	Acoustic Noise	MTBF @ 40°C (hours)	SF200-24	No	N/A	414,166	SF200-24P	1	40.2 dB	307,098	SF200-24FP	2	40.2 dB at 45°C	314,444.5 (based on 45°C)	SF200-48	No	-	267,865	SF200-48P	2	41.7 dB	174,966	SG200-08	No	-	71,834	SG200-10FP	No	-	287,436 (based on 45°C)	SG200-08P	No	-	69,003	SG200-16	No	-	68,033	SG200-28	No	-	194,278	SG200-28P	1	40.2 dB	218,842	SG200-28FP	2	40.2 dB at 45°C	319,407 (based on 45°C)	SG200-50	2	41.7 dB	237,810	SG200-50P	4	42.5 dB at 30°C 54.7 dB at 40°C	208,978	SG200-50FP	4	42.1 dB at 30°C 55.9 dB at 50°C	192,790 (based on 45°C)
Model	Fan (Number)	Acoustic Noise	MTBF @ 40°C (hours)																																																														
SF200-24	No	N/A	414,166																																																														
SF200-24P	1	40.2 dB	307,098																																																														
SF200-24FP	2	40.2 dB at 45°C	314,444.5 (based on 45°C)																																																														
SF200-48	No	-	267,865																																																														
SF200-48P	2	41.7 dB	174,966																																																														
SG200-08	No	-	71,834																																																														
SG200-10FP	No	-	287,436 (based on 45°C)																																																														
SG200-08P	No	-	69,003																																																														
SG200-16	No	-	68,033																																																														
SG200-28	No	-	194,278																																																														
SG200-28P	1	40.2 dB	218,842																																																														
SG200-28FP	2	40.2 dB at 45°C	319,407 (based on 45°C)																																																														
SG200-50	2	41.7 dB	237,810																																																														
SG200-50P	4	42.5 dB at 30°C 54.7 dB at 40°C	208,978																																																														
SG200-50FP	4	42.1 dB at 30°C 55.9 dB at 50°C	192,790 (based on 45°C)																																																														
Warranty	Limited lifetime																																																																

#### Package Contents

- Cisco 200 Series Smart Switch
- Power cord (power adapter for 8-port and 10-port SKUs)
- Mounting hardware
- CD-ROM with user documentation (PDF) included
- Quick-start guide

#### Minimum Requirements

- Web browser: Mozilla Firefox version 8 or later; Microsoft Internet Explorer version 7 or later; Safari; Chrome
- Category 5 Ethernet network cable
- TCP/IP, network adapter, and network operating system (such as Microsoft Windows, Linux, or Mac OS X) installed on each computer in the network

## Ordering Information

Table 2 provides ordering information for the Cisco 200 Series Switches. Table 3 gives ordering information for the MFE and MGE transceivers.

Table 2. Cisco 200 Series Switches Ordering Information

Model	Product Ordering Number	Description
<b>Fast Ethernet</b>		
SF200-24	SLM224GT-xx	<ul style="list-style-type: none"> <li>• 24 10/100 ports</li> <li>• 2 combo mini-GBIC ports*</li> </ul>
SF200-24P	SLM224PT-xx	<ul style="list-style-type: none"> <li>• 24 10/100 ports</li> <li>• 2 combo mini-GBIC ports*</li> <li>• PoE support on 12 ports</li> </ul>
SF200-24FP	SF200-24FP-xx	<ul style="list-style-type: none"> <li>• 24 10/100 ports</li> <li>• 2 combo mini-GBIC ports*</li> <li>• PoE support on 24 ports</li> </ul>
SF200-48	SLM248GT-xx	<ul style="list-style-type: none"> <li>• 48 10/100 ports</li> <li>• 2 combo mini-GBIC ports*</li> </ul>
SF200-48P	SLM248PT-xx	<ul style="list-style-type: none"> <li>• 48 10/100 ports</li> <li>• 2 combo mini-GBIC ports*</li> <li>• PoE support on 24 ports</li> </ul>
SF200-48	SLM248GT-xx	<ul style="list-style-type: none"> <li>• 48 10/100 ports</li> <li>• 2 combo mini-GBIC ports*</li> </ul>
<b>Gigabit Ethernet</b>		
SG200-08	SLM2008T-xx	<ul style="list-style-type: none"> <li>• 8 10/100/1000 ports</li> </ul>
SG200-08P	SLM2008PT-xx	<ul style="list-style-type: none"> <li>• 8 10/100/1000 ports</li> <li>• PoE support on 4 ports</li> </ul>
SG200-10FP	SG200-10FP-xx	<ul style="list-style-type: none"> <li>• 10 10/100/1000 ports</li> <li>• 2 combo mini-GBIC ports*</li> <li>• PoE support on 8 ports</li> </ul>
SG200-16	SLM2016T-xx	<ul style="list-style-type: none"> <li>• 16 10/100/1000 ports</li> <li>• 2 combo mini-GBIC ports*</li> </ul>
SG200-24	SLM2024T-xx	<ul style="list-style-type: none"> <li>• 24 10/100/1000 ports</li> <li>• 2 combo mini-GBIC ports*</li> </ul>
SG200-24P	SLM2024PT-xx	<ul style="list-style-type: none"> <li>• 24 10/100/1000 ports</li> <li>• 2 combo mini-GBIC ports*</li> <li>• PoE support on 12 ports</li> </ul>
SG200-24FP	SG200-24FP-xx	<ul style="list-style-type: none"> <li>• 24 10/100/1000 ports</li> <li>• 2 combo mini-GBIC ports*</li> <li>• PoE support on 24 ports</li> </ul>
SG200-48	SLM2048T-xx	<ul style="list-style-type: none"> <li>• 48 10/100/1000 ports</li> <li>• 2 combo mini-GBIC ports*</li> </ul>
SG200-48P	SLM2048PT-xx	<ul style="list-style-type: none"> <li>• 48 10/100/1000 ports</li> <li>• 2 combo mini-GBIC ports*</li> <li>• PoE support on 24 ports</li> </ul>
SG200-48FP	SG200-48FP-xx	<ul style="list-style-type: none"> <li>• 48 10/100/1000 ports</li> <li>• 2 combo mini-GBIC ports*</li> <li>• PoE support on 48 ports</li> </ul>

\* Each combo mini-GBIC port has one 10/100/1000 Ethernet port and one mini-GBIC/SFP Gigabit Ethernet slot, with one port active at a time.



Table 3. Service and Support Ordering Information

Service Ordering Number	Description
CON-SBS-SVC2	3 years support, software updates, Small Business Support Center access via online, telephone, or community, next-business-day advance replacement

Table 4. MFE and MGE Transceiver Ordering Information

Product Ordering Number	Description
<b>MFE Transceivers</b>	
MFEBX1	100BASE-BX-20U SFP transceiver for single-mode fiber, 1310 nm wavelength, supports up to 20 km
MFELX1	100BASE-LX SFP transceiver for single-mode fiber, 1310 nm wavelength, supports up to 2 km
MFEFX1	100BASE-FX SFP transceiver for multimode fiber, 1310 nm wavelength, supports up to 10 km
<b>MGE Transceivers</b>	
MGBBX1	1000BASE-BX-20U SFP transceiver for single-mode fiber, 1310 nm wavelength, supports up to 40 km
MGBLH1	1000BASE-LH SFP transceiver for single-mode fiber, 1310 nm wavelength, supports up to 40 km
MGBLX1	1000BASE-LX SFP transceiver for single-mode fiber, 1310 nm wavelength, supports up to 10 km
MGBSX1	1000BASE-SX SFP transceiver for multimode fiber, 850 nm wavelength, supports up to 650 m

### A Powerful Foundation for the Basic Business Network

As you strive to make your business more competitive and efficient, every dollar counts. Cisco 200 Series Smart Switches give you just the right the features, performance, and reliability you need, without making you pay for advanced features you don't. With Cisco 200 Series switches, you can rest assured that your business applications and communications tools are resting on a strong technology foundation, so you can focus on achieving your business goals.

#### For More Information

To find out more about Cisco 200 Series Smart Switches, visit [www.cisco.com/go/200switches](http://www.cisco.com/go/200switches).

To learn about other products and solutions in the Cisco Small Business portfolio, visit [www.cisco.com/go/smallbusiness](http://www.cisco.com/go/smallbusiness).



Americas Headquarters  
Cisco Systems, Inc.  
San Jose, CA

Asia Pacific Headquarters  
Cisco Systems (USA) Pte. Ltd.  
Singapore

Europe Headquarters  
Cisco Systems International BV Amsterdam,  
The Netherlands

Cisco has more than 200 offices worldwide. Addresses, phone numbers, and fax numbers are listed on the Cisco Website at [www.cisco.com/go/offices](http://www.cisco.com/go/offices).

Cisco and the Cisco logo are trademarks or registered trademarks of Cisco and/or its affiliates in the U.S. and other countries. To view a list of Cisco trademarks, go to this URL: [www.cisco.com/go/trademarks](http://www.cisco.com/go/trademarks). Third party trademarks mentioned are the property of their respective owners. The use of the word partner does not imply a partnership relationship between Cisco and any other company. (1110R)

# IPPWR16

## 16 Port Gb PoE+ Surge Protection

02/10/12

PRODUCT SPECIFICATION

### Description

The IPPWR16 is designed to provide 16 channels of surge protection for network devices. It can be used with both PoE+ and non-PoE devices. The IPPWR16 is cost-effective and ideally suited for protecting multi-input devices such as a network switch, NVR, or groups of IP cameras or servers. The IPPWR16 is rack mountable in a standard 19" rack. It installs in minutes and provides a single easy access point for grounding.

### Features

- Provides 16 channels of surge protection
- Works with PoE+ and non-PoE 10/100/1000 equipment
- Gigabit PoE+ power
- Fits standard 19" rack cabinets
- Easy to install

### Specifications

Size	2 RU
Connection Method	Standard RJ45 (16 In - 16 Out)
Transient Response Time	1 picosecond typ.
Peak Pulse Power Dissipation	3,000 W/pair (10/100µs)
Clamping Voltage	58V (on all lines)
Network Type	10/100/1000 PoE+ or non-PoE
Temperature	-40°C to +85°C
Shipping Weight	

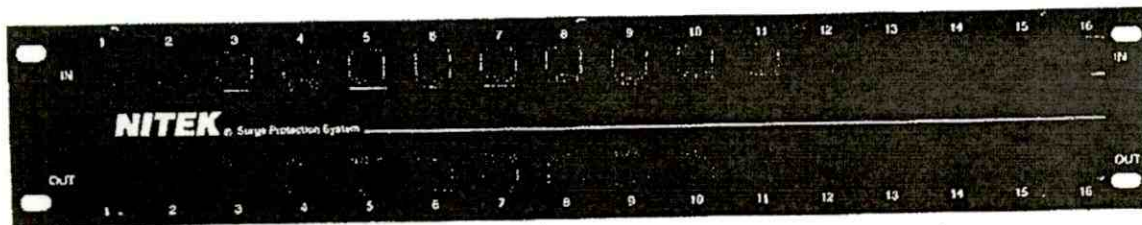

IPPWR16 Front Panel

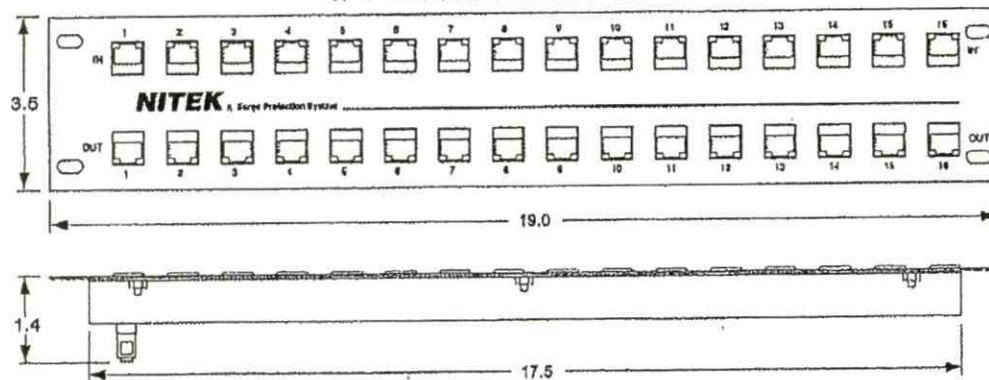

IPPWR16 Bottom View



# NITEK

<p><b>USA</b></p> <p>6410 Newport Drive, # 24 Rolling Meadows, IL, 60008 Phone: (847) 259-8900 Fax: (847) 259-1300 E-mail: info@nitek.net WWW.NITEK.NET</p>	<p><b>EUROPE</b></p> <p>De Schans 19-21 2a 8231 KA Lelystad Tel: +31(0)320-230005 Fax: +31(0)320-282186 E-mail: info@nitek.nl WWW.NITEK.NL</p>
---	--

## PowerProtect Platform

Entry Level

---

# POWERCHOICE LP

Salient's PowerChoice LP (low profile) delivers performance and faster response in a 1U rack mount chassis form factor for space-constrained installations. Available in storage configurations of 2TB, 4TB, 6TB, 8TB, 12TB, and 16TB, the LP is engineered for the rigors of continuous duty operations in video surveillance. Utilizing best-in-class components, enhanced memory and highly efficient power supply, the PowerChoice LP combines value engineering with long-term reliability for mission critical security deployments.

### FEATURES

- Record, live view, playback, archive video
- Hybrid NVR for analog (max 32 channels) and IP cameras
- 1U, rack mount form factor

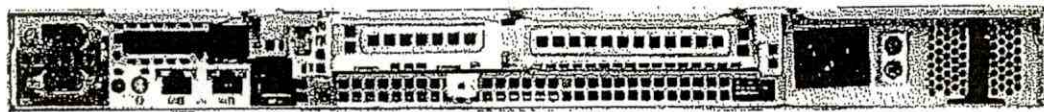

# POWERCHOICE LP

## SYSTEM SPECS

Operating System	Windows 7 Embedded	Graphics Adapter	Integrated
Processor	Intel Core i3	Video Display Ports	1 VGA (front), 1 VGA (rear)
Memory	4GB	USB Ports	2 USB 2.0 (front), 2 USB 3.0 (rear)
Network	Dual 1Gbe NICs	Other Ports	1 serial port (rear)
Hybrid Capable	Up to 32 direct connected analog cameras	Optical Drive	Optional external USB attached DVD-RW
IP Camera Support	Yes	Accessories	Keyboard, mouse & rail kit included
Hard Drive (OS)	OS volume on video storage (no separate OS drive)		
Hard Drive (Video Storage)	2TB, 4TB, 6TB, 8TB, 12TB, or 16TB		

## CHASSIS FEATURES

Form Factor	1RU Rackmount
Height	1.68 inches (4.28 cm)
Width	17.09 inches (43.4 cm)
Depth	19.5 inches (49.7 cm)
Weight	19.32 lb (8.77kg) max

## OPERATING ENVIRONMENT

Operating Temp.	50°F - 95°F (10°C - 35°C)
Power Supply	250W - 100 to 240 VAC auto ranging
Relative Humidity	
Operating:	10% - 80% non-condensing
Storage:	5% - 95% non-condensing
BTU	1039 BTU/hr

## WARRANTY

3 and 5 year (basic)

Company and product names mentioned are registered trademarks of their respective owners. Salient Systems reserves the right to change specifications without prior notice. Copyright Salient Systems, 11/2017





City of Houston  
Houston Information Technology Systems

Telecommunications Cabling Systems Standards

Revision 2.0

June 25, 2015

Table of Contents

Purpose.....4

Applies To.....4

Background.....4

1. Standard.....5

    1.2 The Houston Information Technology Services Responsibility for Telecommunication Projects.....5

    1.3 The Telecommunications System Design and Install Process for the City of Houston.....7

2. Functional Requirements.....8

    2.1 General Requirements.....8

3. The Horizontal Segment.....9

    3.1 Overview.....9

    3.2 Design Process.....9

    3.3 Type and Configuration of Outlets.....10

        Cable Types and Lengths.....11

    3.4 Termination Hardware Requirements at Outlet.....13

    3.5 Workstation Identification.....13

    3.6 Data Patching/Cross Connecting Workstations.....14

    3.7 Structures for Supporting the Horizontal Cabling.....14

    3.8 Cable Testing and Procedures.....17

4. The Riser Segment.....21

    4.1 Overview.....21

    4.2 The Size of the Fiber Optic Cable.....21

    4.3 Structure to Support Vertically Aligned IDF's.....21

    4.4 Structures to Support Horizontally offset IDF's.....22

5. The Campus and Main Segments.....23

    5.1 The Design Process.....23

    5.2 Cable Distribution.....24

    5.3 Underground Conduits and Direct Buried Cable Requirements.....24

    5.4 Cable Types.....27

6. The Telecommunications Closet.....30

    6.1 The Design Process.....30

    6.2 The Size of the IDF.....30

    6.3 The Location of the IDF.....30

    6.4 Design Requirements.....31

    6.5 Minimum Electrical Requirements for the IDF.....32

    6.6 Termination Hardware Requirements in the IDF.....33

    6.7 Structures to Support the Cabling in the IDF.....34

7. The Main Telecommunications Closet.....35

    7.1 Overview.....35

    7.2 The Design Process.....35

    7.3 Design Requirements.....35

    7.4 The Size of the MDF.....36

    7.5 The Location of the MDF.....37

    7.6 Termination Hardware Requirements in the MDF.....38

    7.7 Structures to Support the Cabling in the MDF.....39

    7.8 Cable Pathway Entering the MDF.....40

8. Special.....	41
9. Sample Drawings.....	41
Wall.....	42
Rack.....	43
Rack II.....	44
10. Wavier.....	45

<b>HOUSTON INFORMATION TECHNOLOGY SERVICE (HITS) STANDARDS</b>	No. Page 4 of 45
	<b>Domain</b> Network & Telecom
<b>Title</b> <b>Telecommunications Cabling System Standards</b>	<b>Effective Date</b> June 18, 2015

**PURPOSE**

The purpose of the Telecommunications Cabling System Standards is to define a set of guidelines for deploying and managing the growing environment in the City of Houston. The Telecommunications Cabling System Standards is to establish an efficient, logical, cost-effective and strategic foundation for the support of the physical communications layer installed for the City's telecommunications systems. Following this standard will ensure that citywide installation of all telecommunications cabling infrastructure - both inside and outside - will meet end-user needs, current industry safety standards, technical and performance specifications, and warranty requirements for all systems and equipment. This document is to be used as a minimum guideline.

Future revisions of this standard will be made when competing industry efforts indicate a clear direction is established, based upon industry-wide acceptance of standards.

**APPLIES TO**

These standards apply to departments, architects, contractors, and design professionals who are involved in telecommunications cabling projects for the City of Houston. These standards should be used for all projects involving provision of telecommunications cabling and services.

**BACKGROUND**

A structured cabling system is defined as the complete collective configuration of cabling and associated hardware at a given site that has been installed to provide a comprehensive telecommunications infrastructure. This infrastructure is intended to serve a wide range of usage, such as to provide telephone service or computer networks and should not be device dependent.

This document also assumes that the user is familiar with telecommunications distribution systems, with the cable and hardware used within, and with the installation of cabling in many different environments; including, but not limited to, LANs, MANs, WANs and campus distribution systems. It is not intended to be a training manual in telecommunication distribution systems or to replace existing industry standards.



## STANDARD

- 1 The application of standards and guidelines for telecommunications cabling systems remains facility sensitive. The size, architecture, location and intended use of a facility can significantly affect the particular design of the telecommunications cabling system for a building or campus. The design for specific facilities should be developed by the staff of HITS as part of the normal facilities design, review and approval process. HITS will always assist staff in evaluating both standard practices and alternatives, recommending telecommunications design solutions that are technically appropriate to meet the department's present operational and business needs, and those of the foreseeable future.

Changes and updates to this document will be made as necessary to keep it current with standard industry practices.

- 1.1.1 Requests for a waiver of these standards, or for technical clarification of specific design issues must be forwarded to HITS, who will review all requests in a timely and professional manner:
- 1.1.2 Work performance and standards must warrant that the installation of all materials shall be completed in a professional manner and in accordance with the highest standards of the telecommunications industry.
- 1.1.3 All work and materials shall be in full accord with the requirements of the City of Houston Fire Department, the National Electric Code and other applicable City and state laws or regulations. Nothing in the specifications shall be construed to permit work not conforming to these codes and orders.

### 1.2 The HITS Responsibilities for Telecommunications Projects

- 1.2.1 HITS is responsible for City of Houston inside and outside telecommunications system facilities, network connectivity and the associated backbone cabling. These responsibilities include the review of all telecommunications cabling project plans. These responsibilities are outlined below.
- 1.2.2 HITS will indicate, on the design drawings and in the design specifications, the locations and specifications of the physical infrastructure required for a complete telecommunications cabling pathway and distribution system. This infrastructure shall include:
  - a) Identifications and Workstation locations
  - b) Connectivity for a complete telecommunications cabling system, including connecting hardware and cabling requirements
  - c) The infrastructure necessary to support the horizontal and riser cabling systems
  - d) The required telecommunications IDF/MDF size and locations

- e) The necessary infrastructure to interconnect buildings: including routes, conduit, manholes, pull boxes and building entrances, cables, splices, D-marco points.
- f) Grounding and bonding requirements

1.2.3 HITS shall be provided copies of the Telecommunication Service Request (TSR) or other such documents describing the approved project. These documents shall be provided to HITS upon approval of the department responsible for managing that project.

1.2.4 HITS shall be provided Schematic Design (SD) documents for review at each stage of the schematic design process, and be provided a minimum of five workdays from the date documents are received by HITS for review and return of comments.

1.2.5 HITS shall be provided Design Development (DD) documents for review at each stage of the design development process, and be provided a minimum of ten workdays from the date documents are received by HITS for review and return of comments.

1.2.6 HITS shall be provided Construction Documents (CD) for review at each stage of the construction document process, and be provided a minimum of ten workdays from the date documents are received by HITS for review and return of comments.

1.2.7 When a new project, building or building renovation is planned, architectural drawings are typically released for review by HITS in the following order:

- a) Schematic - These are the initial planning documents and design drawings that assist departments in the early stage of the project. The Schematic Design documents shall consist of system narrative, including MDF/IDF information, and campus connection points.
- b) The schematic design documents should also include drawings composed of a title sheet, single line diagrams, and site plans. These plans may be part of the overall site and or electrical plan.
- c) Design Development -- As the architectural design process progresses, overlays are developed to show the various structures and systems planned for the building. Design Development documents shall consist of outline specifications. Drawings should include title sheet, single line diagram site plan, enlarged floor plans of the proposed MDF/IDF and details.
- d) Construction Documents -- These documents depict the final design before bid submittal is undertaken. The Construction Documents shall consist of a completed cabling specification and drawing set.
- e) Working Copy -- This is the Bid Copy.

- f) Final Documentation and Drawings- these drawings and documents represent the project as it is finally constructed and delivered prior to final inspection of the project.

### 1.3 The Telecommunications System Design and Install Process for the City of Houston

These specifications provide a minimum configuration that must be used when planning new construction, remodeling and or any ADDS, MOVES, OR CHANGES of an existing facility. HITS must be consulted during the early planning phase of the project. Each project may have technical requirements requiring a modification of these specifications.

1.1.1 City of Houston's telecommunications distribution system design process is broken down into six segments:

- a) The **Functional Requirements** explains the functional vision that the City of Houston has planned for in the future.
- b) The **Horizontal Segment** consists of the workstation outlets, cabling to the IDF and all associated pathways
- c) The **Riser Segment** refers to the riser cable, and the sleeves, slots, and conduits that enable the cable to pass from floor to floor: Main IDF(MDF) to the IDF's
- d) The **Campus Segment** or **Metropolitan Area Network (MAN)** refers to the cabling and infrastructure that interconnect buildings and or systems on a campus or within a metro area.
- e) The **Intermediate Distribution Frame (IDF)** contains the hardware i.e., patch panels, and punch down blocks and racks for terminating the cabling from the workstation outlets, electronic equipment, and riser cables.
- f) The **Main Distribution Frame (MDF)** is the room that houses common system equipment and hardware for terminating the campus and riser cables.
- g) **Special Systems**

## 2 FUNCTIONAL REQUIREMENTS

### 2.1 General Requirements

- 2.1.1 In general, this document refers to the physical elements required to support data or any other hardware systems within a specific environment.
- 2.1.2 Information is provided; nonetheless, it shall be the HITS's responsibility to confirm or determine the specific telecommunications infrastructure that will be required to support the required voice and data cable systems.
- 2.1.3 It is anticipated that the cable plant will be required to support Data needs for the next 5 to 10 years.
- 2.1.4 New intra-building Data station cable will be required to support anticipated communications systems. This cabling will distribute to hard wall offices and modular furniture workstations. This station cable must support initial requirements for 100BaseT or higher, 10/100, and potential future requirements, e.g., ATM and Gigabit Ethernet.
- 2.1.5 All new intra-building backbone copper cables and fiber optic composite (multimode) cables will be required between the floor building entrance facility and the MDF. The multimode fiber is intended primarily for data networking purposes; however it will be capable of supporting additional (e.g., energy management, broadband, base band video, etc.) communications services.
- 2.1.6 Complete testing of intra-building backbone copper and fiber cable is required to insure that all fiber strands and copper pairs will accommodate the anticipated communications systems.

### 3 THE HORIZONTAL SEGMENT

#### 3.1 Overview

- 3.1.1 All intra-building Data and LAN cable systems will support high-speed data network requirements. Complete testing must be done on all horizontal cabling and backbone cabling between the MDF/IDF, Building entrance and workstations. Below ceiling cable will not be acceptable.
- 3.1.2 All data applications, 4-pair UTP CAT5E on existing sites and CAT6 or fiber optic cables shall be run using a star topology from the telecommunications closet (IDF) on each floor to every individual workstation and information outlet. All cable routes shall be approved by HITS prior to installation of the cabling.
- 3.1.3 All horizontal cables, serving the floor areas, shall originate from this one MDF/IDF and shall travel above the ceiling to their destination.
- 3.1.4 This station cable shall be installed in cable trays, hard walls, and surface mount raceways and communications poles. I.e.: J hooks & Velcro ties
- 3.1.5 In hard wall offices, cables are to be routed within walls. At modular furniture workstations (cubicles), route station cables within cubicle chases (when available) to non-metallic faceplates. When cubicle chases are not available, spiral-wrapped cable to furniture surfaces.

#### 3.2 The Design Process

- 3.2.1 The horizontal segment consists of two elements:
  - a) The horizontal cable and connecting hardware that provide the means for transporting the telecommunications signals between the work station outlet and the horizontal cross-connect in the IDF.
  - b) The horizontal cabling pathways and spaces that distribute and support the horizontal cable and connecting hardware between the work station outlet and the IDF and from IDF to IDF.
- 3.2.2 Horizontal cables will not be connected directly to telecommunications equipment. Suitable connecting hardware (i.e. patch panels/cords and punch-down blocks) and equipment cables must be used to make the connection.
- 3.2.3 Installation of cable must meet all specifications identified in the applicable TIA/EIA Commercial Building Wiring Standards. Care must be taken to avoid excessive bending radii and to not over pull, micro bend, kink, or over bend cable during installation.
- 3.2.4 Care is required in the management of the station cable as it enters telecommunications closets. All cables must be neatly organized, routed and

secured with Velcro wraps to the cable support systems and management hardware in an aesthetically pleasing manner. Cable must have the appearance of being combed, with no tangles. Cable overlap must be kept to a minimum.

- 3.2.5 All Category 5e and CAT 6 cable shall be tested per Category 5e and CAT 6 performance level standards.
- 3.2.6 IEEE termination standards for Category 5e and CAT 6-station cable must be followed for termination at IDF patch panels and at station jacks. Specific care must be taken to maintain pair twists up to point of termination, or no less than within 1/2" of termination.
- 3.2.7 Horizontal UTP cable at any time will not be spliced.
- 3.2.8 All conductive cabling and associated components must comply with NFPA 70 Article 800 of the NEC (1999). Furthermore, all fiber optic cabling must comply with Article 770 of the NEC (1999)
- 3.2.9 The following information given will to be used to assist HITS in its design and install activities.

This section will describe the procedures for the installation and design activities relating to:

- a) Identify the type and number of outlets in the work area.
- b) Identify the type equipment used in the work area.
- c) Determine termination hardware requirements at the outlet
- d) Design the structures needed to support the horizontal cabling. Sketch the route of the conduit and the cable tray on the floor plan.
- e) Assign and document the work station identification numbers to the appropriate locations.
- f) Verify that the distance from each outlet to the IDF does not exceed 295 feet. This distance must include the planned cable path as well as any vertical transitions.
- g) Cable testing and procedures
- h) Documentation and drawings

### **3.3 The Type and Configuration of Outlets**

- 3.2.1 Work area outlets at the City of Houston fall into three general configurations:

- a) The *basic data only* design supports data and IPT applications. It consists of 1 single jack RJ45 within the work station outlet supported by one 4-pair plenum unshielded twisted pair (UTP) Category 5e and CAT 6 cable.

Note: A *basic data only* workstation outlet may be used applications such as server farms, labs and computer room environments.

- b) The *standard* design support system includes data and 10/100-switched applications. It consists of one RJ45 jack per workstation outlet.

Note: This will become most commonly used configuration at the City of Houston as of June 2001.

Note: The features of these three designs may be combined in the most cost-effective manner with HITS's written approval.

### Cable Types and Lengths

3.3.1 City of Houston recognizes two types of cables for use in the horizontal segment:

- a) Unshielded twisted pair (UTP) cable will be 4-pair plenum, 24 AWG, solid conductor blue Category 5E cabling that meets or exceeds all of the latest ANSI/TIA/EIA 568-A and TIA/EIA 568-A-1
- b) Fiber optic cable: single mode and multi-mode, graded index, and loose and tight-buffered cable.

(i) Approved manufacturers for copper and fiber are:

- (ii) Ber-Tek
- (iii) Remece
- (iv) Corning Cable
- (v) Seicor
- (vi) Comscope
- (vii) Mohawk
- (viii) System Max

Or an HITS approved equal.

3.3.2 All station cables shall be Category 6 plenum 4-pair unshielded twisted pair (UTP) copper cable on new installations. No substitutions will be accepted. On existing locations that have CAT5E installed, CAT5E can be used.

3.3.3 All cables shall be installed per EIA/TIA 568B building standards to designated stations. Data cable shall be terminated on Category 6 patch panels within the IDF and on Category 6 rated RJ-45 modular jacks at the station end. On existing CAT5E sites, CAT5E patch panels and modular jacks may be used.

- 3.3.4 The maximum lengths of horizontal distribution cables from the workstation to the IDF will not exceed 295 feet.
- 3.3.5 Patch cords and cross-connect jumpers in the IDF will not exceed 16 feet
- 3.3.6 All cabling will be UL Listed Type CMP if it is placed in air-handling plenums without conduit. The cable sheath will be marked with the UL listing. (**Note: all indoor cable will be plenum rated**)
- 3.3.7 All patch cords cables and cross-connect that attach directly to active equipment and must meet the same performance requirements as the installed cabling system
- 3.3.8 Care must be taken to maintain minimum bending radii and to avoid kinking when dressing excess cable at termination locations.
- 3.3.9 Cable service loops must be provided at both ends of cable runs to accommodate future cabling system changes.
- 3.3.10 The minimum amount of slack must be 10 feet at both ends for UTP cables and 15 feet for fiber optic cables at the work area outlet. At the MDF and IDF, slack will remain the same as the work area.
- 3.3.11 Service Loops placed during installation of 4-pair horizontal cables should be coiled neatly above the ceiling and attached to building support.
- 3.3.12 Service Loops placed during installation of fiber optic cables should be coiled neatly above the ceiling in a large loop configuration that will meet the manufactures, minimum bend radius requirements.
- 3.3.13 The service loops must be included in all testing and length calculations to ensure that the horizontal cable does not exceed 295 feet.



### **3.4 Termination Hardware Requirements at the Outlet**

3.4.1 Each data UTP plenum Category 5e and CAT 6 cable will terminate all 4 pairs at the outlet with an RJ45 8-pin, 8-conductor universal T568A/B modular jack.

CAT5E inserts will be Red in color. CAT 6 inserts will be Green in color

- a) Approved manufactures
- b) Panduit
- c) Avaya

a) Faceplates for any designated outlets must be from the same manufacture with coinciding part numbers for the jacks being used.

### **3.5 Workstation Identification**

3.5.1 The workstation identification numbers are assigned by HITS. They are crucial to the implementation of service to the project.

3.5.2 Pre-assign the workstation identification numbers to the floor plans.

3.5.3 The HITS will need to know how many Data workstation identification numbers are required.

3.5.4 Each workstation identification number will be pre-assigned by HITS, prior to any bid or installation.

3.5.5 The HITS will provide the unique 8-digit workstation identification numbers. This number is referred to as a workstation identification number or workstation Id.

3.5.6 Prepare workstation identification cut sheets.

3.5.7 Ensure that a cross connect sheet is provided which identifies all cross connects from the workstation identification to the IDF and to the MDF.

3.5.8 Workstation identifications are to be labeled either on a pre-printed label or they must be printed using computer-generated labels or a label maker. No workstations identification numbers will be hand written labels. Hand written labels will be accepted.

3.5.9 Each workstation identification number will be unique.

3.5.10 After workstations identification numbers have been pre-assigned to the floor plans, HITS will then input workstations identification numbers into the City of Houston cable management database.

- 3.5.11 Workstations identification numbers are to be completed at the beginning of Construction Document preparation. A hardcopy of the workstations identification numbers shall be provided to the installation team, as well as an Excel 2010 spreadsheet file is to be provided to HITS upon completion of the installations.
- 3.5.12 HITS will ensure that specifications are placed in the contract documents that inform the installation team regarding use of and maintenance of the workstations identification numbers for the project.
- 3.5.13 Workstations identification numbers will be configured as follows: Building, Floor, North/South/East/West when applicable and workstation outlet.
  - a) Sample: 1A-A001
- 3.5.14 All cables shall be labeled with a computer-generated label within 6" of the Jack and within 2 to 4" from the Patch Panel.
- 3.5.15 The workstation identification number will be placed above the workstation identification on the faceplate, outlet and cubical area. HITS will provide locations for the workstation Id's.
- 3.5.16 When a surface mounted outlet is used the top of the outlet will be labeled. .

### **3.6 Data Patching /Cross Connecting workstations**

- 3.6.1 HITS's PM shall ensure that the Installers and or Contractors will provide Data workstation identification cut sheet.
- 3.6.2 The installer and or contractor shall provide the Data workstation cut sheets to HITS PM as part of the final documentation.
- 3.6.3 The Data workstation cut sheets shall be provided prior to final inspection and acceptance of the cabling work being done.
- 3.6.4 All Data patch cords will be UTP **stranded** category 6 and 5E on existing sites, non-booted.
- 3.6.5 All patch cords cables and cross-connect that attach directly to active equipment must meet the same performance requirements as the installed cabling system.

### **3.7 Structures for Supporting the Horizontal Cabling**

- 3.7.1 **General:** Structures for Supporting the Horizontal Cabling and for determining and providing the required materials (e.g., freestanding and wall mount relay racks, cabinets, mounting brackets, cable runway, J-hooks, cable management hardware, mounting hardware, wraps, etc.) for supporting the systems herein described.

- 3.7.2 Special attention must be given when designing and installing the type and layout of structures to support the horizontal cabling. The design and install must accommodate all foreseeable cabling changes needed for future capacity and applications.
- 3.7.3 The City of Houston requires that the spaces above the ceiling grid and or under a raised floor be used to route the horizontal cabling.
- 3.7.4 Hard walls, wall molding, and Power poles will be used at the work area. Per customer approval.
- 3.7.5 Relay racks: Freestanding relay racks, Heavy Duty 19" x 84", drilled sides per EIA/TIA with universal thread standards, properly anchored and grounded will be used. Wall mount racks will only be used with HITS written approval.
- a) Approved manufactures
  - b) Panduit
  - c) Bee Line
  - d) Chatsworth
- For 2 post racks – minimum of 6 inch wide vertical wire management will be used.
- For 4 post racks – minimum of 8 inch wide vertical wire management will be used.
- For 2 and 4 post racks 4U horizontal wire management will be used unless otherwise specified.
- 3.7.6 Open ceiling cabling: When cable tray is not feasible to install, cable supports ( J-HOOKS) shall be used. J Hooks must be installed by means that is structurally independent of the suspended ceiling, its framework, or supports. These cable supports shall be spaced no more than 5 ft apart.
- 3.7.7 Cable Tray: Cable trays must be aluminum trays or corrugated ventilated trays. They must be at least 12 inches wide and 2 inches deep. Smaller buildings and secondary tray sections serving fewer than 50 work areas may utilize a 12 inch wide tray.
- 3.7.8 In the IDF where cable trays or cable racking are used, the appropriate means of cable management such as reusable Velcro cable managers (cable ties) to create a neat appearing and practical installation must be provided
- 3.7.9 Cable trays must be secured on 10-foot centers using dual mounted steel supporting rods, angled wall supports, or a standard trapeze type support system.
- 3.7.10 Cable trays will be used only over areas with ceiling access and must transition to a minimum of three 4-inch conduits when routed over fixed ceiling spaces larger than 10 feet in length.

- 3.7.11 Cable trays must be grounded and bonded end-to-end.
- 3.7.12 Cable trays must extend into and down to the IDF to protect cables from potential damage.
- 3.7.13 All cable tray penetrations through firewalls must allow cable installers to fire-seal around the cables after they are installed. Mechanical firestop systems will be used when a cable tray must penetrate a fire barrier.
- 3.7.14 Cable trays will not be placed within 5 inches of any overhead light fixture and within 12 inches of any electrical ballast.
- 3.7.15 Cable trays will not run above and parallel to the building lighting system.
- 3.7.16 A minimum clearance of 8 inches above the cable tray must be maintained at all times. All bends and joints in the cable trays must be fully accessible.
- 3.7.17 Conduits: Conduit is to be sized appropriately for the fill of cable it is to accommodate.
- 3.7.18 Hard walls: A 1-inch EMT conduit containing 4 cables or larger if appropriate can be used from the workstation outlets, stub into the above ceiling.
- 3.7.19 All firewalls and or bearing walls will require a minimum 4" conduit sleeve for access between the wall.
- 3.7.20 All conduits will be fire stopping accordance with fire codes as interpreted by the City of Houston Fire Marshal.
- 3.7.21 All firewalls shall be properly sleeved with metallic chases terminated with connectors and plastic bushings, and fire stopped per local fire codes with a re-entenable compound. Sleeves shall have connectors and plastic bushing on both ends and are properly anchored to walls (e.g., anchored unistrut with strut clamps).
- 3.7.22 Conduit will be installed with a pull string with a minimum test rating of 200 pounds.
- 3.7.23 The ends of all conduits installed will be reamed and bushed to eliminate sharp edges that can damage cables during installation.
- 3.7.24 Conduit runs must be designed and installed to:
  - a) Follow the most direct route possible with no more than two 90° bends between pull boxes

- b) Contain no continuous sections longer than 100 feet. Pull boxes must be used for runs that exceed 100 feet in length.
- c) Be bonded to ground on one or both ends.
- d) Conduit must not be run through areas in which flammable materials may be stored or over or adjacent to boilers, incinerators, hot water lines, or steam lines.

3.7.25 Bend Radius:

3.7.26 The radius of a conduit bend must be at least 6 to 10 times the diameter of the conduit, depending on its size. Choose the bend radii for conduit using the following.

- a) 2 inches or less, 6 times the internal conduit diameter
- b) 2 inches or more, 10 times the internal conduit diameter

Note: For additional information on conduit bend radius requirements and recommendations, see specifications in ANSI/NFPA 70 and ANSI/EIA/TIA 569. The guidelines used by ANSI/EIA/TIA-569 on cable capacity for horizontal conduit that have no more than two 90° bends. The diameter of the conduit increases incrementally as the run approaches the IDF from the furthest outlet. This is based on 40% fill ratio.

3.7.27 Back Boxes, Mud rings:

3.7.28 New Construction: A 4' 4' 2½ inch back box with a single gang plaster ring must be used at each work area for cable installations.

3.7.29 For existing installations a metal single gang box eliminator will be required.

### 3.8 Cable Testing and Procedures

- 3.8.1 General: This section describes performance tests required for Acceptance of newly installed cables. Tests shall be conducted in accordance with TIA/EIA Standards. All installed cables are to be tested.
- 3.8.2 These tests are designed to detect damage or errors that may have occurred in the manufacturing, placing or splicing of cable.
- 3.8.3 Cables with bad pairs must be properly labeled and documented in a manner, which clearly identifies the cable pairs tested and test(s) failed. Materials and installation should be of a high quality, which minimizes the number of bad pairs in any cable.
- 3.8.4 No bad pairs will be accepted in any cable.

- 3.8.5 Acceptance Criteria: Prior to acceptance, installed cable must be thoroughly tested to demonstrate that all materials and installation will meet performance specifications.
- 3.8.6 No cables with bad fibers will be accepted. Cables not meeting the manufacturer performance specifications and those, and may be additionally described herein, must be replaced.
- 3.8.7 Basic Guidelines for Loss Measurements for Installed Fiber Optic Cables:
- a) Connector loss: 0.75 dB per mated pair
  - b) Fiber signal loss: Multi-mode: 2.5 dB/km @ 850 nm, 2.5 dB/km @ 1300 nm
  - c) Fiber signal loss: Single mode: 1.0 dB/km @ 1310 nm
- 3.8.8 Optical source meter is stabilized and has a center wavelength within  $\pm 20$  nm of the multi-mode nominal wavelength.
- 3.8.9 Power meter and the light source are set to 850 nm if testing multi-mode fiber or 1310 if testing single mode fiber.
- 3.8.10 These tests are designed to detect damage or errors that may have occurred in the manufacturing, placing, connectorizing or the splicing of cable. The following tests must be conducted as described below and in the following order.
- a) On-Reel (OTDR) Testing: Optical Time Domain Reflectometer (OTDR) testing shall be conducted on all fibers to detect damaged or attenuated fibers.
  - b) On-reel uni-directional test shall be conducted prior to installation of cable to assure the integrity and length of all fibers. Hard copies of OTDR strip reports, at 850 nm for multimode fiber, must be submitted to HITS prior to removal from reels.
  - c) OLTS Testing: Optical Loss Test Set (OLTS) testing shall be conducted for all installed multimode fibers to measure end-to-end attenuation, and installed length. Testing for multimode fiber shall be conducted Bi-directionally at 850 nm and 1300 nm. Certified test records of all OLTS test results shall be provided as documentation and will become part of the "as-built" record.
  - d) Optical Time Domain Reflectometer (OTDR) testing will be accepted as a substitute for OLTS or light meter tests and shall be conducted on all multimode and single mode fibers to detect damaged or attenuated fibers.
- 3.8.11 Acceptance Testing for Data Station Cabling: Testing will be done on all installed and terminated voice and data cables. Cable tests are to be conducted to ensure that the engineering design is achieved in the actual construction and that transmission quality meets specifications

and objectives described herein. These tests are designed to detect damage or errors that may have occurred in the placing or termination of the cable.

- 3.8.12 All submitted test result documentation indicating "pass" condition with notations indicating any required repairs. Test result documentation shall be dated and signed by test technician and shall be neatly bound.
- 3.8.13 Data Category 5e and CAT 6 Cable Testing: performance measurement. Complete 4-pair testing is required in both directions for the following characteristics:
  - a) Near-end-cross talk (NEXT)
  - b) Mapping
  - c) Attenuation-to-Crosstalk Ratio (ACR)
  - d) Length
  - e) Resistance
  - f) Impedance
  - g) Attenuation
  - h) Capacitance
- 3.8.14 Use of test equipment with a two-way injector that measures NEXT and ACR simultaneously from both cable ends of the link will preclude the requirement for bi-directional testing.
- 3.8.15 HITS requires that all Category 5E and CAT 6 cable pairs must be tested at a minimum using a Category 5 Level II or Level III tester for full compliance with Category 5e and CAT 6 specifications regardless of intended use.
- 3.8.16 All field-testing must comply with the **worst case** EIA/TIA 568B Commercial Building Telecommunications Wiring specification and must be used as a framework for testing all UTP cables at the City of Houston.
- 3.8.17 Documentation of Test Results:
- 3.8.18 For testers that will document results in electronic and printed form: Hard and soft (prints/disk) copies of all test results shall be provided as documentation and will become part of the "as-built" record. One set of all test results shall be neatly bound and provided prior to systems acceptance.
- 3.8.19 For all cables, test documentation must include the following:
- 3.8.20 All voice and data Category 5 test results are to be documented on a HITS approved testing sheet, along with Category 5 tester generated test results sheets.
- 3.8.21 All testing must include confirmation of continuity and proper pair terminations and that pairs are free of shorts, crosses, opens and polarity reversals

- 3.8.22 OTDR trace printouts and disk copy must be provided for all fibers installed and tested.
- 3.8.23 OLTS results are to be documented on installer-provided and HITS approved result worksheet.
- 3.8.24 All submitted test results and documentation indicating "pass" condition must have notations indicating any required repairs. Test result documentation shall be dated as to when the test was completed. Completed data test results shall be sent to the HITS PM.



## **4 THE RISER SEGMENT**

### **4.1 Overview:**

4.1.1 The Building entry Telecommunications Main Point of Presence serves as the building point of entry and the main inter-building termination point for communications services. These facilities then get extended into the Main IDF(MDF)/Server room

4.1.2 The building riser system provides copper and optical fiber connectivity between the MDF and the MDF and from the MDF to the IDF. (Building Entrance Facilities to Computer room.

4.1.2.1 The riser segment consists of the riser cable and the supporting infrastructure within a building or cluster of buildings that connect the and the building distribution frame (MDF)

### **4.2 The Size of the Fiber Optic Riser Cable**

4.2.1 The size of the fiber optic cable from the MDF to the IDF will be no less than a 12-strand multimode.

### **4.3 Structures to Support Vertically Aligned IDF's**

4.3.1 IDF that are vertically aligned must be connected with sleeves. A sleeve is a circular opening through the ceiling or floor of a IDF that allows the passage of cables and wires.

4.3.2 3 4" sleeves it the IDF is minimum.

4.3.3 Sleeves and slots must be positioned with in 12" of a near wall on which the riser cables can be supported.

4.3.4 Sleeves are not be placed directly above or below the termination fields.

4.3.5 All sleeves installed must conform to the National Electrical Code (NEC) and local fire codes.

4.3.6 Sleeves must not be left open after cable installation and they must be properly fire-stopped at all times in accordance with all applicable building codes.

4.3.7 Sleeves must extend a minimum of 4 inches above the floor level.

4.3.8 Sleeves shall have connectors and plastic bushings on both ends and be properly anchored to walls (e.g., anchored unistrut with strut clamps)

- 4.3.9 Rigid conduit sleeves must be 4 inches in diameter unless a structural engineer requires a smaller size or obstructions are present. They must be fitted with plastic bushings on both ends and equipped with pull strings.
- 4.3.10 All unused sleeves must be filled and capped.
- 4.3.11 In a multi-story building, cable grips must be specified to support the riser cable's weight as it passes through the IDF.
- 4.3.12 The minimum number of 4-inch sleeves that must be used based on the total feet that the sleeves support.
- 4.3.13 Up to 50,000 sq. = 4, 4"
- 4.3.14 50,000 to 100,000sq.= 5, 4"
- 4.3.15 100,000 to 300,000sq.=5-8, 4"

#### 4.4 Structures to Support Horizontally Offset IDF

- 4.4.1 HITS recommends stacking all IDF within a building, HITS also understands that there are times when this cannot be met.
- 4.4.2 IDF that are not vertically aligned must be connected with cable trays and or conduits.
- 4.4.3 Determine the number of conduits required. This number is the same as the number of sleeves required if the IDF had been vertically stacked.
- 4.4.4 Pull boxes are required in sections of conduit that are 100 feet or more in length or that contain more than two 90° bends. Pull boxes must not be used in lieu of a bend.
- 4.4.5 Cable trays and conduit that are used to support horizontal cabling may be used to support riser cables provided the following conditions are met:
  - a) The cable trays' carrying capacity can accommodate the riser cables.
  - b) The riser cables must be UL Listed Type CMP or OFNP if they are run in a air-handling plenums without conduit.
  - c) The riser cables conform to NEC Article 800-3(b)(1), NEC Article 800-3(b)(3), and comply with the State of California fire codes as interpreted by the State Fire Marshal's department.
  - d) Conduit will be used to route the riser cables between the IDF.
  - e) Cable tray can be used if the Horizontal cable and riser cable are in separate tray.

- f) Conduit will be grounded at each end.
  - g) Conduit will be installed with a true tape and bushings at both to protect the cable from damage
- 4.4.6 Cable trays and conduits that enter the IDF must be placed near the corner and as close as possible to the wall where the backboard is mounted to allow for proper cable racking and to minimize the cable route inside the IDF.
  - 4.4.7 Cable trays and conduit located in the ceiling must protrude into the IDF 1 to 2 inches and above 7 1/2 feet above the finished floor.
  - 4.4.8 Conduit must be grounded using a path other than the telecommunications ground provided in the IDF.
  - 4.4.9 All riser cables are to be labeled based on a cable number assigned by HITS. The number of cable pair will also be included in this label.

## **5 THE CAMPUS and MAN SEGMENTS**

### **5.1 The Design Process**

- 5.1.1 These specifications provide a minimum configuration that must be used when planning a campus or Metropolitan Area Network (MAN) segments. HITS must be consulted during the early utilities planning phase of a project to provide technical requirements that require a modification of these specifications.
- 5.1.2 The campus and Metropolitan Area Network (MAN) segments consists of the cables and structures needed to inter-connect building to building and building to metro area distribution frames (MADFs). It includes underground conduit, underground cables, direct buried cables, splice boxes, manholes, pull boxes, aerial cables, pole lines, outside terminals, and support structures.
- 5.1.3 This section describes the activities for identifying cable routes from building to building selecting cable distribution methods, determining the underground and direct buried cable requirements identifying the types of cable used in the segment, determining splice boxes, manholes, pull boxes requirements, determining aerial cable requirements and satisfying electrical protection and bonding/grounding requirements
- 5.1.4 All campus and MAN segments must be designed and installed to BICSI, Customer-Owned Outside plant manual and ANSI/EIA/TIA-758 Specifications for Outside Plant Construction.
- 5.1.5 The cable routes steps must be taken to identify the routes between new buildings and major building renovations.
- 5.1.6 Obtain a MAN and or campus layout drawing.

- 5.1.7 Determine where the cable entrance points are for each building.
- 5.1.8 Sketch the cable route from the starting point to the terminating point in the buildings to be served.
- 5.1.9 Note any obstacles, existing cable facilities, or other underground utilities on the campus layout map.
- 5.1.10 Note and document all of the right-of-ways and easements, to determine if permits required.
- 5.1.11 Review proposed cable route to determine if conditions exist that require would require an environmental impact. Identify all possible sources of future cable maintenance problems.

## **5.2 Cable Distribution**

- 5.2.1 HITS and City of Houston engineers must be contacted to determine the best cable distribution method along a proposed cable route. The methods used may be one or a combination of the following.
  - a) Underground cable in conduit
  - b) Direct buried cable
  - c) Directional boring,
  - d) Aerial.
- 5.2.2 Underground cable systems consists of cables placed in buried conduits, using manholes and/or pull boxes for splices in large runs. The conduit runs from the building entrance location to a pole, pedestal, or manhole. HITS recommend that all outside plant cabling be placed in conduits.
- 5.2.3 Direct buried cable systems consist of cables and associated splices directly placed in the earth. The trench runs from the building entrance location to a pole, pedestal, or manhole. This is not an HITS recommended distribution method.
- 5.2.4 Aerial cable systems is installed on aerial supporting structures with messenger cable such as poles, sides of buildings, and other above ground structures.

## **5.3 Underground Conduits and Direct Buried Cable Requirements.**

- 5.3.1 Underground cabling in conduit and direct buried cable projects must be worked from engineering drawings approved by HITS and EAS (Engineering and Architectural Services).
- 5.3.2 All submitted drawings and documentation must include the following information.

- a) Submittals and/or details of a typical trench cross sections showing cable and duct locations in the trench, clearances from final grade, backfill materials and depths, pavement cutting information, and compacting requirements for both paved and unpaved areas.
  - b) Construction notes applicable to the work being performed.
  - c) Scale drawings showing location ties to existing structures, cable, conduit, utility boxes, and any conflicting substructures and profile drawings of congested areas where vertical and horizontal separation from other utilities is critical during cutting and placing operations and any other areas as requested by HITS.
  - d) Legends explaining symbols of all relevant structures and work operations.
  - e) Cable types counts, and directions of feed.
  - f) Conduit types, dimensions, and wall-to-wall measurements when used with pull boxes splice boxes, manholes.
  - g) Manhole drawings showing cable-racking information, applicable cable counts conduit assignments, splicing details, north point arrows, and street names. Manhole drawings must be consistent with HITS standards.
- 5.3.3 All areas around the conduit entrances must be free of any construction, storage, or mechanical apparatus.
- 5.3.4 Conduit stubs entering the building must extend beyond the foundational landscaping. All conduit ends adjacent to the building must be flagged for easy identification
- 5.3.5 All entrance conduits must be securely fastened to the building to withstand a typical placing operation.
- 5.3.6 All unused entrance conduits must be capped and installed with pull strings
- 5.3.7 Conduit entering from a below grade point must extend 4 inches above the finished floor.
- 5.3.8 Conduit entering from ceiling height must terminate 4 inches below the finished ceiling.
- 5.3.9 All cables entering a building must conform to the grounding and bonding requirements listed in NEC Articles 250 and 800.
- 5.3.10 Conduit must be positioned on the field side of the poles. The field side refers to the side that is protected from the normal flow of traffic.

- 5.3.11 All utilities need be identified and located prior to any digging. This is to locate all subsurface facilities such as power, gas, water, traffic and outdoor lighting.
- 5.3.12 Warning tape color orange for the telecommunications cables containing metallic tracings must be placed a minimum of 18 inches above the buried conduits and or cables to minimize any chance of an accidental dig-up.
- 5.3.13 The minimum depth of a trench must allow 24 inches of cover from the top of the cable to the final grade point. See NEC 300-5 for condition pertaining to other depths.
- 5.3.14 The following minimum vertical or horizontal separations that must be maintained between telecommunications facilities and other facilities sharing a common trench.
- a) Power or other foreign conduits: 3" of concrete, 4" of masonry, or 12" of well-tamped earth.
  - b) Pipes such as gas, oil, water: 6" when crossing, 12" when parallel
  - c) Railways: 3' below top of rails.
- 5.3.15 Conduit must be encased in concrete when the following conditions exists:
- a) Minimum conduit depth cannot be attained
  - b) Conduit must pass under roads, driveways, railroad tracks, or when bend points are subject to movement.
- 5.3.16 Reinforcing bars and or crutches within the concrete must be used at any location subject to potentially extreme stress.
- 5.3.17 The inside-the-building end of the conduit must be sealed to prevent rodents, water, or gases from entering the building.
- 5.3.18 All bends must be long, sweeping bends with a radius not less than 6 times the internal diameter of a conduit 2 inches or smaller, or 10 times the internal diameter of a conduit larger than 2 inches.
- 5.3.19 Conduit must be PVC Schedule 40, corrosion-resistant plastic with a 4 inch inside diameter
- 5.3.20 There must be no more than two 90° bends between pulling points on all entrance cables
- 5.3.21 Conduit bends that extend above ground are to be metallic.
- 5.3.22 All metallic conduit and sleeves must be reamed, bushed, and capped.

5.3.23 Metal sleeves through foundation floors and or walls must extend to undisturbed earth to prevent shearing.

5.3.24 All open conduits must be provided with a # 12 Tracer wire with a minimum pull tension of 200+ pounds.

5.3.25 The City of Houston minimum number of conduits standard for any installation of cable will be:

a) 3 -4" conduits, 2 open, 1 filled with 2-1.5 inch 1-1 inch interducts.

5.3.26 The quantity and size of underground entrance conduit are based on the anticipated number and type of telecommunications circuits that will be brought into the building. HITS requires 2 entrance pairs per 100 square feet of usable office space. The following shows the data for determining the quantity and size of underground entrance conduit.

5.3.27 Telephone Entrance Copper Pairs Conduit Required

a)	1 - 1000	1 each 4-inch conduit + 2 spare 4-inch conduit
b)	1001 - 2000	2 each 4-inch conduit + 2 spare 4-inch conduit

5.3.28 Fiber optic Entrance Cable Conduits Required

a)	2-48 strand Interducts	1 each 4-inch conduit + 2 spare 4-inch conduits + 3
b)	48+ Interducts	2 each 4-inch conduit + 2 spare 4-inch conduits + 3

5.3.29 If installing both fiber and copper cable utilize the City of Houston minimum standard.

5.3.30 All conduits containing interducts must be provided with a # 14 Tracer wire.

#### 5.4 Cable Types

5.4.1 HITS recognizes two types of cable for outside use in the campus and MAN segments; copper cable and fiber optic cable.

5.4.2 Indoor/Outdoor copper and fiber cable will be used in all outside plant installs.

5.4.3 Filled polyethylene-insulated conductor (PIC) cable must be used for direct buried copper cable. Filled cable preserves the integrity of the cable by providing physical protection against moisture penetration and seepage.

5.4.4 Direct buried cable requires an armored sheath to resist rodent and penetration type damage.

- 5.4.5 All cables must be marked with cable length, cable code, date and location of manufacture, and manufacturer.
- 5.4.6 The following standard designations for copper exchange cable have been assigned by the Rural Utilities Services (RUS): PE-39 refers to filled cable with solid insulation for direct-buried applications. PE-89 refers to filled cable with an expanded insulation for direct-buried applications.
- 5.4.7 Indoor/Outdoor Fiber Optic Cable Construction is to be:
- 5.4.8 Optical fibers shall be placed inside a loose buffer tube. The nominal outer diameter of the buffer tube shall be 3.0 mm.
- 5.4.9 Each buffer tube shall contain up to 12 fibers.
- 5.4.10 The fibers shall not adhere to the inside of the buffer tube.
- 5.4.11 Each fiber shall be distinguishable by means of color coding in accordance with TIA/EIA-598-B, Optical Fiber Cable Color Coding.
- 5.4.12 The cable shall contain at least one ripcord under the sheath for easy sheath removal of all-dielectric cable.
- 5.4.13 The cable shall contain at least one ripcord under the inner sheath and under the steel armor for armored cable.
- 5.4.14 The dielectric yarns shall provide tensile strength. The high tensile strength dielectric yarns shall be helically stranded evenly around the cable core.
- 5.4.15 All dielectric cables (non-armored) shall be sheathed with medium density polyethylene (MDPE).
- 5.4.16 Armored cables shall have an inner sheath of MDPE. The armor shall be a corrugated steel tape, plastic-coated on both sides for corrosion resistance, and shall be applied around the outside of the water blocking tape with an overlapping seam with the corrugations in register.
- 5.4.17 The MDPE jacket material shall be as defined by ASTM D1248, Type II, Class C and Grades J4, E7 and E8.
- 5.4.18 All cable jackets or sheaths shall be free of holes, splits, and blisters.
- 5.4.19 The cable jacket shall contain no metal elements and shall be of a consistent thickness.
- 5.4.20 Cable jackets shall be marked with manufacturer's name, sequential meter or foot markings, month and year or quarter and year of manufacture, and a



telecommunication handset symbol, as required by Section 350G of the National Electrical Safety Code (NESC).

- 5.4.21 The actual length of the cable shall be within  $-0/+1\%$  of the length markings.
- 5.4.22 The cable jacket of a cable containing two different fiber types (hybrid construction) shall be marked to indicate quantity of each fiber type, identity of each fiber type, and the fiber sequence.
- 5.4.23 The maximum pulling tension shall be 2700 N (608 lbf) during installation (short term), and 890 N (200 lbf) long term installed.
- 5.4.24 Performance Single Mode:
- 5.4.25 Chromatic Dispersion
  - 5.4.25.1 Minimum Zero Dispersion Wavelength: 1301.5 nm
  - 5.4.25.2 Maximum Zero Dispersion Wavelength: 1321.5 nm
  - 5.4.25.3 Maximum Zero Dispersion Slope: 0.090 ps/nm<sup>2</sup> per km
- 5.4.26 Dispersion:
  - 5.4.26.1  $<-3.2\text{ps}/(\text{nm.km})$  from 1285 nm to 1330 nm
  - 5.4.26.2  $<18\text{ ps (nm.km)}$  at 1550 nm
  - 5.4.27 Polarization Mode Dispersion:  $<- 0.5\text{ ps/km}$
- 5.4.28 Attenuation:
  - 5.4.28.1 Point Discontinuity:  $<-0.10\text{ dB}$  at 1310 nm or 1550 nm
  - 5.4.28.2 Water peak attenuation at 1383 (+-) 3nm :  $<- 2.1\text{ dB/km}$
  - 5.4.28.3 Bending Attenuation: induced @ 1550 nm, with 100 turns on 75mm diameter mandrel  $>0.10\text{dB}$
  - 5.4.28.4 Water Immersion: Induced attenuation, 23 degrees C water immersion:  $<- 0.05\text{dB/km}$
  - 5.4.28.5 HITS approved manufacturer
    - a) Corning
    - b) Seicor
    - c) Bertek
    - d) Hitachi
    - e) Or approved equal.
- 5.4.29 Multimode Performance:
  - 5.4.30 Bandwidth: (1) 850 nm  $>220\text{ MHz}$  at 1 km (2) 1300 nm  $> 600\text{ MHz}$  at 1 km

#### 5.4.31 Chromatic Dispersion:

- 5.4.31.1 Minimum Zero Dispersion Wavelength 1332 nm
- 5.4.31.2 Maximum Zero Dispersion Wavelength: 1354 nm
- 5.4.31.3 Maximum Zero Dispersion Slope: 0.098 ps/nm<sup>2</sup>.km

5.4.32 Attenuation: Max attenuation point discontinuity: <0.2 dB at any design wavelength.

5.4.33 Bending Attenuation: induced @ 1550 nm, with 100 turns on 75mm diameter mandrel: <0.10dB.

5.4.34 HITS approved manufacturer

- a) Corning
- b) Ber-Tek
- c) Hitachi
- d) Or approved equal.

## 6 THE TELECOMMUNICATION CLOSET

### 6.1 The Design Process

- 6.1.1 Overview: The IDF is the space where the data horizontal cable is terminated on patch panels,
- 6.1.2 The IDF supports the data, and other low voltage needs of one floor of a building.
- 6.1.3 The IDF may also be used to support other building information systems such CATV, alarms, security, audio/Video, 800 MHz radio, other wireless systems, and other telecommunications low voltage systems.
- 6.1.4 A MDF and IDF can be collocated within the same room. Additional space, racks, electrical and cable management are required to support the MDF.

### 6.2 The Size of the IDF

- 6.2.1 The size of the IDF depends on its function and the size of the usable floor space it will serve.
- 6.2.2 Usable floor space refers to the occupied areas used for normal daily work functions.
- 6.2.3 There must be at least a minimum of one IDF per floor

- 6.2.4 Multiple IDF are required if the usable floor space to be served exceeds 10,000 square feet or the cable length between the work area outlet and the horizontal cross-connect in the IDF exceeds 295 feet or 90 meters.
- 6.2.5 Additional floor space in the IDF will be required for additional applications such as Video Distribution cabling, equipment, fire alarm panels and/or building monitoring equipment.
- 6.2.6 The minimum IDF sizes shown are based on providing telecommunications service to one individual work area of 100 sq. ft. Minimum IDF sizes are as follows:
  - a) 5,000sq. or less = 10 × 8 finished room size
  - b) 5,000 to 8,000= 10 × 10 finished room size
  - c) 8,000 to 10,000= 10 × 12 finished room size

### 6.3 The Location of the IDF

- 6.3.1 Since the IDF is the main focal point for many communications services located for a specific floor, it must be designed as an integral part of the overall building.
- 6.3.2 The IDF must be located as close as possible to the center of, and on the same floor as, the workstation area it serves; this will minimize the horizontal cable lengths.
- 6.3.3 Access to the IDF must be located directly from hallways, not within classrooms, offices, and electrical or mechanical spaces.
- 6.3.4 The IDF must be located above any threat of flooding. All water threats must be removed or contained. IDF with a water threat located within the space at a minimum and if approved by HITS will require a drain.
- 6.3.5 At no time is a IDF to be located near power supply transformers, elevator or pump motors, generators, radio transmitters, and other potential sources of electromagnetic interference.
- 6.3.6 IDF must not share space with electrical, janitorial, or storage facilities.
- 6.3.7 IDF must be stacked vertically in a multi-story building. Special conditions will need prior approval from HITS.
- 6.3.8 When secure and controlled access to an IDF cannot be guaranteed, free standing or wall mounted lockable cabinets will be used.
- 6.3.9 At all time the locations of the IDF must be submitted for inclusion in the construction drawings, and they must be annotated on any and all floor plan.

#### 6.4 Design Requirements

- 6.4.1 Major factors that must be considered when designing the IDF are as follows:
- 6.4.2 Minimum ceiling height must be 8 feet, 6 inches.
- 6.4.3 The doors must be a minimum of 3 feet wide and 6 feet, 8 inches tall. The doors must be lockable.
- 6.4.4 The floor must be sealed concrete or a VCT type tile to minimize dust and static electricity.
- 6.4.5 There must be continuous and dedicated environmental control (24 hours per day, 365 days per year).
  - a) Heating, ventilation, and air conditioning sensors and control equipment must maintain the room temperature between 64° F and 87° F.
  - b) The relative humidity must be 20% to 80%.
- 6.4.6 The IDF must not have a drop tile or other false ceiling.
- 6.4.7 The lighting in the IDF must provide a minimum equivalent of 50 foot-candles when measured 3 feet above the finished floor.
- 6.4.8 All light fixtures must be mounted a minimum of 8 feet, 6 inches above the finished floor.
- 6.4.9 All controls and light switches must be located inside the room.
- 6.4.10 All walls must be lined with 3/4-inch fire treated plywood with stamp clearly visible, 8 feet high, as measured 3" from finished floor.
- 6.4.11 3/4-inch AC Grade plywood can be used if painted with two coats of white fire-retardant paint.
- 6.4.12 The plywood must be securely fastened to the wall-framing members.

#### 6.5 Minimum electrical requirements for the IDF are as follows:

- 6.5.1 A minimum of four dedicated 3-wire 120V AC quad electrical outlets on separate branch circuits and 20-ampere rated.
- 6.5.2 Separate duplex 120V AC convenience outlets (for tools, test sets, vacuums, etc.) installed at least 18 inches above the finished floor at 6-foot intervals around perimeter walls.

- 6.5.3 Each IDF must be provided with an electrical ground on a system and building sized buss bar as defined by NEC Article 250-71(b).
- 6.5.4 Buss bars must be mounted 6 feet, 6 inches above the finished floor if ladder racking is included in the design. If ladder racking is not part of the design,, buss bars must be located near, but not behind, the riser sleeves between floors.
- 6.5.5 This grounding bar must be connected to a main building ground electrode, and it must be common to all IDF. *Reference ANSI/ELA/TIA-607.*
- 6.5.6 All grounding systems must be provided in the IDF, MDF and MDF which shall include but not limited to, cable bonding, cabinet and relay rack ground kits with #6 THHN wire, ground busses, and ground clamps.
- 6.5.7 All grounds are to be installed per ANSI/TIA/EIA-607, *Grounding and Bonding Requirements for Telecommunications in Commercial Buildings.*

#### 6.6 Termination Hardware Requirements in the IDF

- 6.6.1 They must be wall mounted or rack mounted in either equipment racks or enclosed data cabinets.
- 6.6.2 Space for terminations of each type of cable must be located on one continuous wall or rack.
- 6.6.3 A clear space of at least 8 inches above and below the connecting hardware must be provided for cabling handling
- 6.6.4 There must be additional backboard space for routing cables, patch cords, and/or cross-connect jumpers
- 6.6.5 The horizontal cabling must be terminated on, RJ45, 110 type, patch panels for data cabling and 110 type punch blocks for the voice cabling, in the IDF.
- 6.6.6 All UTP data cables must be terminated on 24 or 48 fixed-port high density Category 5e patch panels (no 96 port) which are to mounted on wall racks, in a free standing equipment rack, or in an enclosed data cabinet
- 6.6.7 For smaller installations, smaller port density patch panels can be used if approved by HITS.
- 6.6.8 Patch panels must support RJ-45 modules wired to the TIA/EIA 568-B standard on the front, and have 110-style IDC connectors on the back.
- 6.6.9 Patch panels must be clearly labeled with a type or computer generated label above the RJ45 module.

- 6.6.10 The City of Houston approved manufacturer for all data patch panels is
- a) Panduit
  - b) Or a HITS approved equivalent
- 6.6.11 Fiber optic cables will be terminated on Connector panels in a fiber distribution cabinet
- 6.6.12 All terminated fibers shall be properly dressed and mounted in Rack-Mount fiber connect panels. All patch panel bulkhead spaces must contain either connector panels or blank panels.
- 6.6.13 16-gauge heavy steel rack mount patch panels are required
- 6.6.14 The Patch panel connector panels shall contain multimode and or single mode (ceramic ferrule) connector coupling compatible with the ceramic ST connectors.
- 6.6.15 Multimode connector panels must be preloaded with metal inserts.
- a) Approved manufacture
  - b) Panduit
- 6.6.16 The single mode connector panel must be preloaded with 568ST adapters with ceramic inserts. Color of connector shall be blue or beige.
- 6.6.17 A minimum 12 strand Fiber housing units will be used to mount all terminated fiber in the IDF.
- 6.6.18 The fiber-housing unit must be configured with fiber patch cable troughs to assist in cable management.
- 6.6.19 Relay Racks shall be freestanding relay racks, CPI Heavy Duty 19" x 84", drilled both sides per EIA/TIA universal thread standards, and properly anchored and grounded.
- 6.6.20 Cross-connect fields, patch panels, and active equipment in the IDF must be placed to allow all cross-connections and interconnections via jumpers, patch cords, and equipment cables whose lengths per channel do not exceed:
- a) 16 feet per patch cords or jumpers in the horizontal cross-connect.
  - b) 33 feet total for patch cords or jumpers and line cords used to connect to the outlet.

## 6.7 Structures to Support the Cabling in the IDF

- 6.7.1 A 3-foot working clearance must be maintained in the front and in the back of each equipment rack, and a 2-foot working clearance must be maintained at both ends of the equipment rack or rack rows. This clearance must be measured from the outermost surface of the equipment and connecting hardware rather than from

the equipment rack since some of these devices may extend beyond the equipment rack

- 6.7.2 Ladder racking, equipment racks, plywood backboards, data equipment cabinets, and wire management brackets must be used in the IDF to keep the cabling and equipment organized, and to allow the cable plant to be installed to HITS, BICSI distribution methods and EIA/TIA 569 specifications.
- 6.7.3 Ladder racking must be used to route bulk telecommunications cables within the IDF.
- 6.7.4 Ladder racking must be at least 12 inches wide and placed 7 feet above the finished floor to coincide with the top of the equipment racks and/or cabinets.
- 6.7.5 All ladder racking must be bonded and grounded to the ground point in the IDF.
- 6.7.6 Free Standing Equipment racks must be as noted in 5.5.29, 19 inches wide by 84 inches tall, double sided with ANSI/EIA-310D spacing and 12-24 threads.
- 6.7.7 All racks and cabinets must be grounded and bonded to the ground point in the IDF.
- 6.7.8 Equipment and connecting hardware may be wall mounted on a plywood backboard that is permanently attached to the wall and treated with a nonconductive, fire-resistant covering.
- 6.7.9 Wire management brackets must be used to manage cables and jumpers.

## **7 THE MAIN TELECOMMUNICATIONS CLOSET**

- 7.1 Overview: The Main IDF serves as the main inter-building termination point for communications services
  - 7.1.1 The Main IDF/MDF (also known as a computer room) is the room that houses the telecommunications equipment that meets the voice, data, and other low voltage needs of an entire building. This equipment may include Private Branch Exchange (PBX), switching nodes, local area network hubs, and video distribution equipment, and/or network routers
  - 7.1.2 The MDF contains cross-connect facilities for terminating cables and for connecting the horizontal and riser segments to each other and to telecommunications equipment. The MDF may also support other building information systems such as CATV, alarms, security, audio, and other telecommunications systems.
  - 7.1.3 A MDF can be collocated with a IDF, and/or a Building Entry Telecommunications Main Point of Presence. Additional racks, electrical and

cables management will be required. The quantity of additional equipment is dependent upon the quantity of workstations that must be supported.

## **7.2 The Design Process**

- 7.2.1 Whether the space is separated or combined with the building service entrance, it is, by definition, a specialized area. This room will house sensitive electronic components that will generate heat 24 hours a day, 365 days a year, and must be cooled to maintain operating performance.
- 7.2.2 The air handling system for equipment rooms must be designed to provide positive airflow and cooling even during times when the main building systems are shut down. This may require separate air handlers and/or small stand-alone cooling systems that are thermostatically controlled in this space.
- 7.2.3 If this room is to be used as a Metro Area Distribution Facility (MADF), the air handling system should be connected to the building's backup power generation system.
- 7.2.4 Because this room will house sensitive electronic components and is a specialized area, Detailed attention to the design will need to be done.

## **7.3 Design Requirements**

- 7.3.1 Most of the requirements for the MDF are transparent to the IDF.
- 7.3.2 The major factors that must be considered when designing the MDF are as follows:
  - 7.3.3 The minimum ceiling height must be 8 feet, 6 inches.
  - 7.3.4 Ceiling protrusions must be placed to assure a minimum clear height of 8 feet 6 inches to provide space over the equipment frames for cables and suspended racks.
  - 7.3.5 The doors must be double doors that are 6 feet wide by 7 feet, 6 inches tall. The doors shall be keyed and or badge accessible only to the department directly responsible.
  - 7.3.6 The floor must be raised floor, sealed concrete or tile to minimize dust and static electricity.
  - 7.3.7 There must be continuous and dedicated environmental control, 24 hours per day, 365 days per year.
  - 7.3.8 Heating, ventilation, and air conditioning sensors and control equipment must be located in the MDF.



- 7.3.9 The room temperature must be maintained between 64° F and 80° F.
- 7.3.10 The relative humidity must be 30% to 55%.
- 7.3.11 Heat load is 5,000 BTUs per hour average per cabinet, equipment rack.
- 7.3.12 Positive air pressure differential must be maintained with respect to surrounding areas.
- 7.3.13 The lighting in the MDF must provide a minimum equivalent of 50 foot-candles when measured 3 feet above the finished floor.
- 7.3.14 The light fixtures must be mounted a minimum of 8 feet, 6 inches above the finished floor.
- 7.3.15 The light switches must be located inside and near the entrance of the MDF.
- 7.3.16 Power for the lighting must not come from the same circuits as power for the telecommunications equipment.
- 7.3.17 The MDF electrical requirements must be provided based on the equipment needs.
- 7.3.18 Outlets are to be located on active equipment racks 24" AFF.
- 7.3.19 Separate duplex 120V AC convenience outlets (for tools, test sets, etc.) must also be installed at 18 inches above the finished floor at 6-foot intervals around perimeter walls.
- 7.3.20 The MDF must be provided with an electrical ground pursuant to NEC Article 250-71, ANSI/EIA/TIA-607.
- 7.3.21 Acoustic noise levels in the MDF must be maintained to a minimum by locating noise-generating equipment outside the MDF.
- 7.3.22 Additional equipment such as fire alarm panels and/or building monitoring devices must not be housed in the MDF. Separate space for these services can be provided as part of the electrical room or in a separate space.

#### 7.4 The Size of the MDF

- 7.4.1 The size of the MDF depends on the size and variety of the equipment to be installed and the size of the area that the room will serve.
- 7.4.2 The MDF must provide enough space for all planned equipment and cables, including any environmental control equipment, power distribution units/conditioners, and uninterrupted power supply systems that will be installed there.

7.4.3 The MDF must also provide space for access to the equipment for maintenance and administration, and for equipment changes with minimal disruptions.

7.4.4 The MDF should be sized according to the equipment's needs. And not by the square foot print.

7.4.5 The minimum size of the MDF can be determined as follows:

7.4.5.1 In a MDF dedicated to communications and if the environment allows open equipment cabinets or racks, a 19" x 84" space will be utilized with 6" vertical cable management on each side. This equates to a 32" per equipment bay. A minimum of three bays will be installed in any size building with a wall minimum of 10 feet.

7.4.5.2 A minimum of 2 feet shall be left at the end of the row of equipment bays. A minimum of 5 feet between walls and equipment bays will allow space for wall mounted copper cable terminations and the required 36" distance from equipment for workspace.

7.4.5.3 In larger size buildings requiring additional rows of equipment bays, the bays shall be lined up in rows with 5 feet between the rows and walls.

#### 7.5 The Location of the MDF

7.5.1 The MDF must be located as close as possible to the building entrance so that it is accessible for the delivery of large equipment.

7.5.2 The MDF must not be located in any place that may be subject to water or steam infiltration, humidity from nearby water or steam, heat, and any other corrosive atmospheric or environmental conditions.

7.5.3 The MDF must not be located near electrical power supply transformers, motors, generators, transmitters, radar transmitters, induction heating devices, and other potential sources of electromagnetic interference.

7.5.4 The MDF must not share space in or be located near electrical closets, boiler rooms, washrooms, janitorial closets, and storage rooms.

#### 7.6 Termination Hardware Requirements in the MDF

7.6.1 The MDF serves as the main cross-connect common equipment circuits coming from the PBX, and riser cables that extend to the IDF. Campus cables and service provider cables are also cross connected in the MDF.

- 7.6.2 The distribution cabinets must be configured with jumper troughs to aid in jumper management, and they must be racks mounted in either equipment racks or enclosed data cabinets.
- 7.6.3 Cabinets are used in lieu of equipment racks based upon. Security, and cleanliness of the room in which the proposed equipment rack is to be placed.
- 7.6.4 If the communications room is a single use room, for communications access only, and is a secure, heated and cooled space with appropriate lighting, racks can be used in lieu of cabinets.
- 7.6.5 All midsize/larger MDFs and ADFs require cabinets. 4. UTP cables supporting data workstations must be terminated on Category 5e patch panels (see section 6).
- 7.6.6 Space for data terminations must be located on one continuous rack.
- 7.6.7 There must be a clear space of 6 to 8 inches above and below the top and bottom of the connecting hardware for cabling handling.
- 7.6.8 There must be additional backboard space for routing cables, patch cords, and/or cross-connects jumpers.
- 7.6.9 Cross-connect fields patch panels, and active equipment in the MDF must be placed to allow cross-connections and interconnections via jumpers, patch cords, and equipment cables whose lengths per channel do not exceed, 16 feet per patch cords or jumpers in the horizontal cross-connect and 33 feet total for patch cords or jumpers and line cords used to connect to the outlet.

**7.7 Structures to Support the Cabling in the MDF**

- 7.7.1 Some of the Structures to Support the Cabling in the MDF are the same as the IDF (see section 6 for details).
- 7.7.2 Ladder racking, equipment racks, data equipment cabinets, and wire management brackets must be used in the MDF to keep the cabling and equipment organized, and to allow the cable plant to be installed to EIA/TIA 569 specifications.
- 7.7.3 Cable Tray and Ladder racking must be used to route bulk telecommunications cables within the MDF.
- 7.7.4 Cable tray and Ladder racking must be at least 12 inches wide and placed under a raised floor or 7 feet above a finished floor to coincide with the top of the equipment racks and cabinets.
- 7.7.5 Cable Trays and Ladder racking must provide a proper clearance from HVAC ducting or other obstacles.
- 7.7.6 All cable trays and ladder racking must be bonded and earthed.

- 7.7.7 Free Standing Equipment racks must be 19 inches wide by 84 inches tall, double sided with ANSI/EIA-310D spacing and 12-24 threads.
- 7.7.8 Enclosed Cabinets are equipped with 10-32 threads
- 7.7.9 3-foot working clearance must be maintained in the front and in the back of each equipment rack, and a 2 foot working clearance must be maintained at both ends of the equipment rack or multiple rack assemblies. This clearance must be measured from the outermost surface of the equipment and connecting hardware rather than from the equipment rack since some of these devices may extend beyond the equipment rack.
- 7.7.10 The equipment racks must meet, all grounded and bonded requirements to the TGB in the MDF.

**7.8 Cable Pathway Entering the MDF**

- 7.8.1 Sleeves, slots, and conduits are used to route the cables entering and exiting the MDF. The cross-connect points must be located near the end of the riser pathways to minimize the need for cable routing in the MDF.
- 7.8.2 Sleeves must conform to the firestopping requirements as established by the National Electrical Code (NEC) and local fire codes.
- 7.8.3 Sleeves must not be left open after cable installation and they must be properly firestopped in accordance with applicable building codes. All conduits will be firestopped in accordance with fire codes as interpreted by the State Fire Marshal
- 7.8.4 Conduit will be metallic conduit, 4 inches in diameter.
- 7.8.5 The conduit will be grounded on both ends.
- 7.8.6 The conduit will be equipped with a pull string.
- 7.8.7 The conduit ends will be bushed to protect the cable.

## 8 SPECIAL SYSTEMS

- 8.1 Radio Communications equipment and cabling shall be installed in accordance with manufacturer instructions and the Motorola R-56 Quality Standards manual. The City of Houston Cabling System Standards Document will apply in situations where the R-56 manual does not.
- 8.2 Special Circuits. Since special circuits (such as data circuits, T1s, or alarms) are usually non-switched, they shall be treated differently than voice and modem circuits. The protector modules shall be marked to indicate a special circuit. Various colors of protector modules are available to help in this differentiation. The special circuits shall be cross connected to designated blocks on the horizontal side. (Not to the switch blocks).
- 8.3 Coaxial Cable. When CATV or CCTV requirements are identified, either a broadband coaxial cable or single-mode fiber optic cable system shall be installed. When a coaxial system is installed, care shall be taken to ensure the correct cable is used. The table below lists cable type with the corresponding distance limitation.

8.3.1 Cable Distance, RG-6  $\leq$  250 feet

## 9 SAMPLE DRAWINGS

- 9.1 The following drawings are to be used as representations of City of Houston installations, both the Telecommunication closets and workstation information outlets. They are also an example of the final documentation received upon completion of any City of Houston install.

## WAIVER

There may be other circumstances that may require a department to request a waiver from this standard. Specific implementations that require approval of a waiver and coordination with HITS include real-time remote synchronization with, or connection to, an Enterprise network resource; connection to or synchronization with resources on a network other than the City's; or selection of a manufacturer or operating system not cited herein.

In order to be considered for a waiver, a department must:

1. Submit a memo to the Chief Information Officer requesting a waiver to the Standard. The request must include:
  - a. Description of the waiver request.
  - b. Business need that requires a solution not covered by this standard.
  - c. Description of the proposed alternative environment or solution.
  - d. Assessment of risk to the Enterprise or departmental systems, data, or security.
2. The Chief Information Officer will approve or disapprove the waiver request, based on the justification provided in the requesting memo.

Approved by:

---

Chief Information Officer  
(SIGNATURE ON FILE)

## EXHIBIT "D-1"

### Work Letter

This Work Letter (this "Agreement") is made and entered into this \_\_\_\_\_ day of \_\_\_\_\_, 2018, in connection with that certain Lease Agreement (the "Lease") by and between, **MIDTOWN CENTRAL SQUARE, LLC.**, a Texas limited liability company, as Landlord ("Landlord"), and **THE CITY OF HOUSTON, TEXAS**, a municipal corporation situated in Harris, Fort Bend and Montgomery Counties, as Tenant ("Tenant"), and, together with the Lease, constitutes the entire agreement between Landlord and Tenant with respect to the construction and completion of the improvements in and to Leased Premises. All capitalized terms used herein, but not defined herein, shall have the meanings ascribed to such terms in the Lease.

To induce Landlord and Tenant to enter the Lease (which is incorporated herein by reference to the extent that its provisions may apply hereto) and in consideration of the mutual covenants hereinafter contained, Landlord and Tenant mutually agree as follows:

1. Construction Plans. Tenant has provided to Landlord the specifications and space plans for the Leased Premises attached as **Exhibit "D"** to the Lease (the "Tenant Specifications"). Landlord will provide, by Landlord's designated "Architect" and/or "Engineer," and at Landlord's sole cost and expense, the following "Construction Plans," based upon the Tenant Specifications provided by Tenant and drawn for the Leased Premises on Tenant's behalf:

- a. Completed, finished, cable locations and detailed architectural drawings for Tenant's partition layout, ceiling, telephone and electrical outlets, and for the work to be done by Landlord under Paragraph 2 hereof;
- b. Completed plans, where necessary, for installation of air-conditioning grilles and registers, heating, plumbing and electrical facilities for the work to be done by Landlord under Paragraph 2 hereof.

The work required to be performed pursuant to the Construction Plans shall be referred herein to as "Landlord's Work."

When such draft Construction Plans have been completed, Landlord shall promptly deliver them or cause them to be delivered to Tenant. If Tenant has any objections or comments with respect to such draft Construction Plans, Tenant shall notify Landlord of such objections within four (4) business days after receipt of the draft Construction Plans. Tenant's failure to provide the foregoing notification shall be deemed as Tenant's approval of such draft Construction Plans. Landlord, at Landlord's sole cost and expense, shall cause the Architect and/or Engineer to make the requested changes and modifications to the draft Construction Plans that are approved by Landlord (such approval not to be unreasonably withheld, delayed or conditioned), and shall resubmit to Tenant the modified Construction Plans, which shall be subject to the same review, approval and modification procedures set forth above. Notwithstanding the foregoing, if Tenant requires additional modifications to the Construction Plans after the second revision, such additional modifications shall be at Tenant's sole cost and expense, and each day of delay caused by such additional round of modifications shall be considered

one (1) day of Delay (hereinafter defined). The agreed-upon Construction Plans shall be hereinafter referred to as the "Final Plans." The parties must agree upon the Final Plans before the Construction Plans are submitted for building permits.

Landlord, at its sole cost and expense, will cause the Final Plans to be filed with the appropriate governmental agencies in such form (building notice, alteration or other form) as may be required.

2. Landlord's Work. Landlord agrees to perform, at its sole cost and expense (except as otherwise expressly provided herein), Landlord's Work in the Leased Premises, said work to be commenced after Tenant has approved in writing (or has been deemed to approve) the Final Plans. Landlord's Work required to be performed pursuant to the Construction Plans shall include the following:

a. Partitioning. Landlord will furnish and install partitioning in place in accordance with the Tenant Specifications reflected on **Exhibit "D"**.

b. Painting. Landlord will paint all interior partitions with one (1) primer and two (2) finish coats in accordance with the Tenant Specifications reflected on **Exhibit "D"**.

c. Doors, Frames and Hardware. Landlord will furnish and install doors and door frames, including corridor door(s) required by City of Houston Building or Fire Codes, in accordance with the Tenant Specifications reflected on **Exhibit "D"**.

d. Electrical Outlets. Landlord will furnish and install electrical outlets in accordance with the Tenant Specifications reflected on **Exhibit "D"**.

e. Telephone Outlets. Landlord will provide for the installation of wall-mounted telephone outlets in accordance with the Tenant Specifications reflected on **Exhibit "D"**.

f. Light Fixtures. Landlord will furnish and install light fixtures in accordance with the Tenant Specifications reflected on **Exhibit "D"**.

g. Light Switches. Landlord will furnish and install wall switches in each designated office/conference room/storage room/break area in accordance with the Tenant Specifications reflected on **Exhibit "D"**.

h. Ceiling. Landlord will furnish and install ceiling throughout in accordance with the Tenant Specifications reflected on **Exhibit "D"**.

i. Flooring. Landlord will furnish and install floor treatments in accordance with the Tenant Specifications. Landlord shall provide base building carpet at a cost under no circumstances to exceed \$\_\_\_/yard. Any cost in excess \$\_\_\_/yard for such carpeting shall be the sole responsibility of Tenant and shall be paid to Landlord prior to the commencement of Landlord's Work.



j. Window Covering. Landlord will furnish and install mini-blinds on all exterior windows in accordance with the Tenant Specifications reflected on **Exhibit "D"**.

k. Heating, Ventilation and Air-Conditioning. Landlord will ensure that the HVAC system in place on the Occupancy Date is in good working order so that it will perform its intended function and will satisfactorily service the Leased Premises as of the Occupancy Date. The cost of the inspection and, if appropriate, repair or upgrading before the Occupancy Date will be borne by Landlord.

l. Plumbing. Landlord will furnish and install plumbing in accordance with the Tenant Specifications reflected on **Exhibit "D"**.

3. Tenant's Right to Enter Premises to Perform Work. Landlord will permit Tenant and its agents reasonable access to the Leased Premises during normal working hours prior to the date specified for the commencement of Tenant's occupancy under the Lease, in order that Tenant may perform through its own contractors such work and decorations as Tenant may desire at the time that Landlord's contractors are working in the Leased Premises. The foregoing license to enter prior to the commencement of the Lease Term, however, is conditioned upon Tenant's workmen and mechanics working in harmony and not interfering with any person employed by Landlord, Landlord's mechanics or contractor or by any other tenant or that tenant's contractor. Any delay to Landlord's Work caused by Tenant's work at this time will be deemed Delay and will be treated as such as provided for in this Work Letter. Such license is further conditioned upon workmen's compensation and public liability insurance and property damage insurance, all in amounts and with companies and on forms satisfactory to Landlord, being provided and at all times maintained by Tenant's contractors engaged in the performance of the work, and certificates of such insurance being furnished to Landlord prior to proceeding with the work. If at any time such entry shall cause disharmony or interference with Landlord's agents, employees, mechanics or contractors, this license may be withdrawn by Landlord upon forty-eight (48) hours written notice to Tenant. Such entry shall be deemed to be subject to all of the terms, covenants, provisions and conditions of said Lease except as to the covenant to pay Rent. Landlord shall not be liable in any way for any injury, loss or damage which may occur to Tenant, its employees, contractors, agents, workmen and mechanics, or any one or more of them, or to any of Tenant's decorations or installations so made prior to commencement of the Lease Term, the same being solely at Tenant's risk, and Tenant hereby agrees to hold Landlord harmless from any and all claims therefor or arising therefrom.

4. Inspection of Tenant's Work. Landlord and its agents may, at any time inspect any of Tenant's work performed under Section 3 of this Work Letter, to ensure that such work is of acceptable quality and does not conflict with the Final Plans. To the extent that any of Tenant's work is not of an acceptable quality and/or conflicts with the Final Plans, Tenant shall immediately cease such work and at Tenant's sole cost and expense repair or replace the same, as reasonably required by Landlord.

5. Negation of Landlord's Warranties. Except for Landlord's warranties set forth in the Lease, LANDLORD MAKES NO WARRANTIES, EXPRESS OR IMPLIED, INCLUDING, WITHOUT LIMITATION, IMPLIED WARRANTIES OF MERCHANTABILITY AND FITNESS FOR A PARTICULAR PURPOSE, IN CONNECTION WITH THE LANDLORD'S WORK OR ANY OTHER IMPROVEMENTS MADE TO THE LEASED PREMISES OR THE PROJECT. Tenant will also hold Landlord and its property manager and agents harmless from and against any claim, cost, damage,

suit, or liability in respect of any damage or injury to any person arising from any construction activities engaged in by Tenant or any agent or independent contractor thereof (or by any agent or sub-contractor of any such party) other than caused by the gross negligence or willful misconduct of Landlord.

6. For the purposes of this Work Letter and the Lease, the terms "Substantial Completion" or "Substantially Completes" or any similar expression of like import shall mean when (a) the Landlord Work to be performed by Landlord has been completed in accordance with this Work Letter, the Lease, and the Final Plans, except for normal and typical punch list items which do not adversely affect Tenant's use or occupancy of the Leased Premises in any material respect, and (b) Landlord has delivered (or caused to be delivered) to Tenant a Certificate of Occupancy for the Leased Premises from the governmental authority which has authority to issue such certificates in the City of Houston, Texas.

7. For the purposes of this Work Letter and the Lease, "Delay" shall mean any actual delay experienced by Landlord or its developer or contractors in substantially completing the Landlord's Work resulting from Tenant's actions or inactions including, without limitation:

(a) Tenant's failure to complete any action or item or give approval or comments on or before the due date, which is the responsibility of Tenant, pursuant to the schedules set forth herein;

(b) Tenant's request for materials, finishes or installations, other than building standard items for the Leased Premises or the Project, which require lead times greater than those required for building standard items or changes to the Final Plans which are incompatible with the design, construction or equipment of the Leased Premises or the Project; or

(c) Any event expressly identified as Delay in this Work Letter or the Lease.

Each day of delay caused by any of the foregoing shall be considered one (1) day of Delay for the purposes of determining the Occupancy Date under the Lease.

8. Both parties acknowledge that it is Tenant's intent to occupy the Leased Premises on or before February 1, 2019. Accordingly, notwithstanding any provision in the Lease otherwise to the contrary, when Landlord Substantially Completes all of Landlord's Work as described above and delivers the Leased Premises to Tenant, Tenant will execute the Certificate of Commencement and commence paying Rent as specified in the Lease. In all other events, the terms of the Lease shall control.

"LANDLORD"  
MIDTOWN CENTRAL SQUARE, LLC

"TENANT"  
CITY OF HOUSTON, TEXAS

By: \_\_\_\_\_  
Print name: \_\_\_\_\_  
Position: \_\_\_\_\_

By: \_\_\_\_\_  
C.J. Messiah, Jr.  
Director  
General Services Department

## Exhibit "E"

### OPERATING EXPENSES

The following expenses shall be excluded from the definition of Operating Expenses for the purposes of determining the amount of Additional Rent due from Tenant under the Lease:

1. Cost of repairs, replacements, or other work occasioned by fire, windstorm, or other casualty, covered by insurance (but not excluding insurance deductibles), or the exercise by the governmental authorities of the right of eminent domain covered by proceeds received as a result of such action.
2. Leasing commissions, attorneys' fees, costs, disbursements, and other expenses incurred by Landlord or its agents in connection with negotiations for leases with tenants, other occupants, or prospective tenants or other occupants of the Project, and similar costs incurred in connection with disputes with and/or enforcement of any leases with tenants, other occupants, or prospective tenants or other occupants of the Project.
3. "Tenant allowances", "tenant concessions", work letters, and other costs or expenses (including permit, license, and inspection fees) incurred in completing, fixturing, furnishing, renovating, or otherwise improving, decorating, or redecorating space for tenants or other occupants of the Building, or vacant, leasable space in the Project, including space planning/interior design fees for same.
4. Cost for converting chillers in the Project to new chillers that use a coolant other than R11 or other legally prohibited refrigerant as of the date of this Lease, regardless of whether or not such conversion is as a result of a new legal requirement.
5. [Intentionally Omitted].
6. Depreciation, other "non-cash" expense items, or amortization, except for certain amortization charges set forth in the Lease (for instance with respect to capital replacements and repairs as set forth in Article 3 of the Lease).
7. [Intentionally Omitted].
8. Costs in connection with services (including electricity), items, or other benefits of a type which are not standard for the Project and which are not available to Tenant without specific charge therefore, but which are provided to another tenant or occupant of the Project, whether or not such other tenant or occupant is specifically charged therefore by Landlord.

9. Services, items, and benefits for which Tenant or any other tenant or occupant of the Project specifically reimburses Landlord or for which Tenant or any other tenant or occupant of the Project pays third persons.

10. Costs or expenses (including fines, penalties, and legal fees), incurred due to the violation by Landlord, its employees, agents, and/or contractors, any tenant (other than Tenant), or other occupant of the Project of any terms or conditions (other than by Tenant) of this Lease or of the leases of other tenants in the Project, and/or of any valid applicable laws, rules, regulations, and codes of any federal, state, county, municipal, or other governmental authority having jurisdiction over the Project that would not have incurred but for such violation by Landlord, its employees, agents, and/or contractors, it being intended that each party shall be responsible for the costs resulting from its own violation of such leases and laws, rules, regulations, and codes as same shall pertain to the Project.

11. Penalties for late payment, including, without limitation, taxes, equipment leases, etc.

12. Costs directly resulting from the negligence or willful misconduct of Landlord, its employees, agents, and/or contractors.

13. Payments in respect of overhead and/or profit to any subsidiary or Affiliate (hereinafter defined) of Landlord, or to any other party, as a result of a noncompetitive selection process for services (other than the management fee, if any) on or to the Project and/or the land, or for goods, supplies, or other materials, to the extent that the costs of such services, goods, supplies, and/or materials exceed the costs that would have been paid had the services, goods, supplies, or materials been provided by parties unaffiliated with Landlord, or by third parties, of similar skill, competence, and experience, on a competitive basis.

14. Payments of principal, finance charges, or interest on debt of amortization on any mortgage, deed of trust, or other debt, and rental payments (or increases in same under any ground or underlying lease or leases (except to the extent the same may be made to pay or reimburse, or may be measured by, real estate taxes).

15. Except for the management fee, if any, costs of Landlord's general overhead and general administrative expenses (individual, partnership, or corporate, as the case may be), which costs would not be chargeable to Operating Expenses of the Project in accordance with generally accepted accounting principles, consistently applied.

16. Compensation paid to clerks, attendants, or other persons in commercial concessions (such as a snack bar, restaurant, or newsstand), if any, operated by Landlord or any subsidiary or Affiliate of Landlord.

17. Except for emergency or temporary repairs to the Project, rentals and other related expenses, if any, incurred in leasing air conditioning systems, elevators, or other equipment ordinarily considered to be of a capital nature, except equipment which is used

in providing janitorial services and which is not affixed to the Building, to the extent costs are in excess of the savings incurred.

18. Costs incurred in installing, operating, maintaining, and owning any specialty items or services not normally installed, operated, and maintained in buildings comparable to the Project and not necessary for Landlord's operation, repair, and maintenance of, and the providing of required services for, the Project and/or any associated parking facilities, including, but not limited to, an observatory, beacon(s), broadcasting facilities (other than the Project's music system, and life support and security systems), luncheon club, athletic or recreational club, helicopter pad, child care center, kiosks, promotions, displays, concierge, etc.; provided, however, the costs of a video wall or directory display, front desk receptionist and/or concierge, and a security guard or guards shall be included as Operating Expenses.

19. Advertising and promotional expenses.

20. Costs in connection with the ownership, operation, and maintenance of any off-site garage facilities which do not serve the Project.

21. Costs or expenses for sculpture, paintings, or other works of art, including costs incurred with respect to the purchase, ownership, leasing, showing, promotion, and/or repair.

22. Costs for which Landlord is compensated through or reimbursed by insurance or other means of recovery.

22. Costs of correcting or repairing defects in the Project and/or any associated parking facilities, and /or equipment or the replacement of defective equipment, to the extent such costs are covered by warranties of manufacturers, suppliers, or contractors, or are otherwise borne by parties other than Landlord.

24. [Intentionally omitted]

25. Contributions to operating expense reserves.

26. Initial costs of exterior landscaping.

27. Contributions to charitable organizations.

28. Costs incurred in removing the property of former tenants and/or other occupants of the Project.

29. Rental for Landlord's on-site management and/or leasing offices above 1,000 square feet NRA at the Fair Market Rate.

30. Consulting costs and expenses incurred by Landlord except to the extent same relate exclusively to the improved management or operation of the Project.

31. [Intentionally Omitted].

32. Costs or fees relating to the defense of Landlord's title to or interest in the Project and/or Land, or any part thereof.

33. Compensation in the form of wages, salaries, and such other compensation and benefits, as well as any adjustments thereto, for all employees and personnel of Landlord above the level of the on-premises manager of the Project.

34. An equitable allocation of wages, salaries, and other compensation and benefits of Landlord's employees, agents, and personnel work on other projects, including, without limitation, those being periodically developed, managed, and/or operated by Landlord or its agents, in addition to the Project and/or the Land, among all such projects in proportion to their time spent in performing services other than the Office Park.

35. Special assessments, federal, state, county, or municipal taxes on income, death taxes, excess profit taxes, franchise taxes, or any taxes imposed or measured on or by the income, gross receipts, or revenue of Landlord from the operation of the Project or imposed in connection with or as a result of any change in the ownership of the Project and/or Land. (Notwithstanding the foregoing, the Texas Margin Tax on the Project shall be included as set forth in Article 3 of this Lease.)

36. [Intentionally Omitted].

37. [Intentionally Omitted].

38. Any other expense which, under generally accepted accounting principles, consistently applied, would not be considered to be a normal maintenance or operating expense of the Property.

The term "Affiliate" shall mean and refer to any person or entity controlling, controlled by, or under common control with another such person or entity. "Control" as used herein shall mean the possession, direct or indirect, of the power to direct or cause the direction of the management and policies of such controlled persons or entity; the ownership, directly or indirectly, of a least fifty-one percent (51%) of the voting securities of, or possession of the right to vote, in the ordinary direction of its affairs, at least fifty-one percent (51%) of the voting interest in, any person or entity shall be presumed to constitute such control. In the case of Landlord, the term Affiliate shall include any person or entity controlling or controlled by or under common control with any general partner of Landlord or any general partner of Landlord's general partner.

**Exhibit "B-1"**

Space Plan

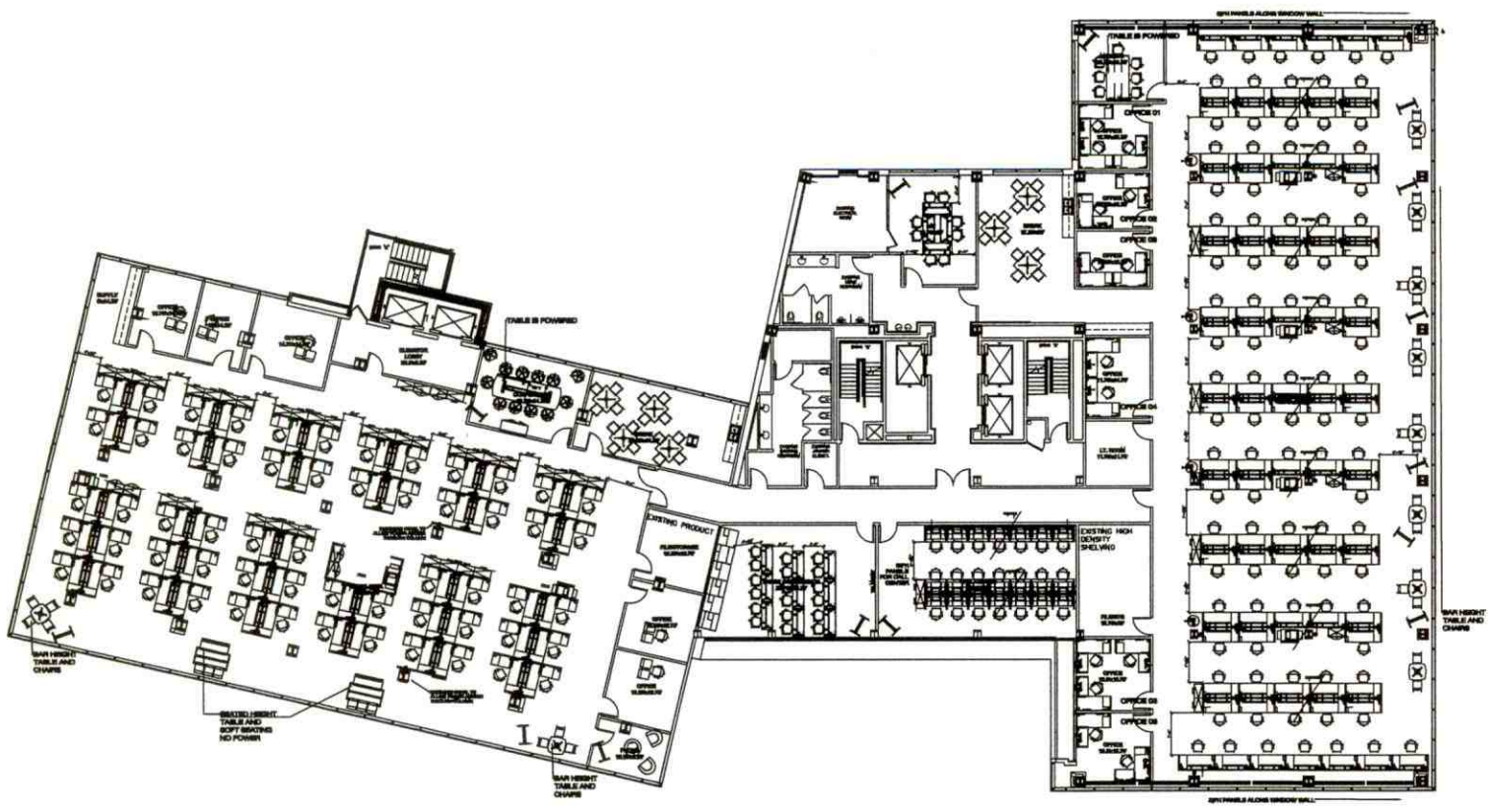

CITY OF HOUSTON  
 PROJECT INFO  
 100 TRAVIS ST  
 LEVEL 04

PROPOSED FURNITURE PLAN  
 OVERALL PLAN

FILE PATH / NAME  
 G:\CAD PROJECTS 2018\CITY OF HOUSTON\2100  
 TRAVIS\LEVEL\_04\1828009P04F.dwg

CLIENT APPROVAL  
 APPROVED  
 APPROVED AS NOTED  
 REVISE AND RESUBMIT  
 APPROVED BY/DATE:



SCALE 1/16" = 1'-0"  
 DATE 7.17.2018  
 DESIGNER KERRY BALLESTY  
 ACCT MGR RANDI SCHRAMM

LEGAL NOTICE:  
 DRAWING AND MATERIAL PRESENTED REMAIN THE PROPERTY OF CONTRACTOR. RESPONSE GROUP AND MAY NOT BE DUPLICATED, USED OR DISCLOSED WITH THE CONSENT OF CONTRACT RESPONSE GROUP. NOT FOR REGULATORY APPROVAL, PERMITTING OR CONSTRUCTION. DUE TO CITY CODE ON NEW CONSTRUCTION, ALL ELECTRIFICATION OF EXISTING FURNITURE PRODUCTS MUST BE PERFORMED BY A LICENSED ELECTRICIAN AND RETENTION OF SAME IS THE CLIENT'S RESPONSIBILITY.



**Exhibit "D-1"**

Space Plan & Specifications

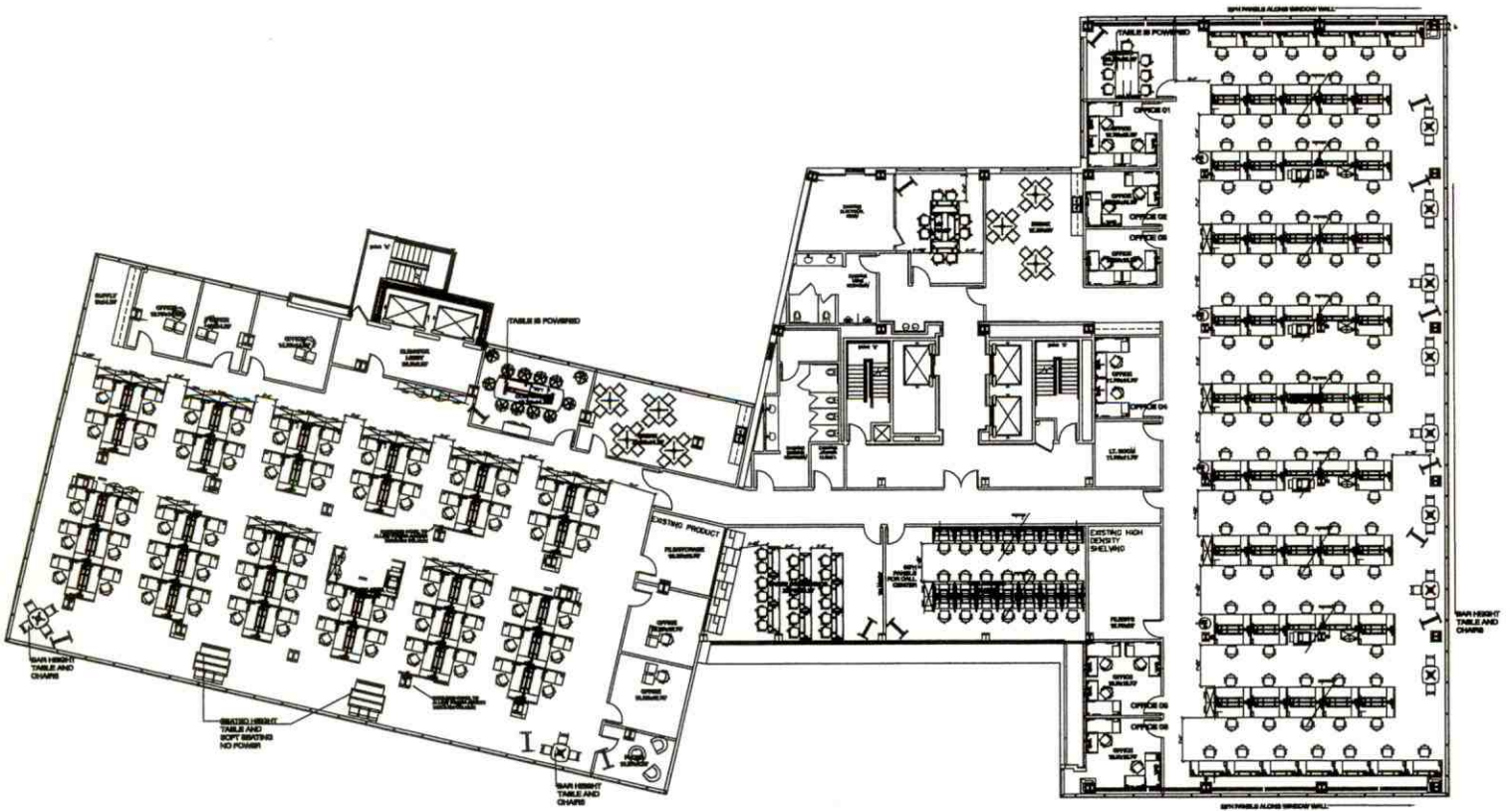

**CITY OF HOUSTON**  
 SUBJECT INFO  
 186 TRAVIS ST  
 VEL 04

**PROPOSED FURNITURE PLAN  
 OVERALL PLAN**

FILE PATH / NAME  
 Q:\ICAP PROJECTS 2018\CITY OF HOUSTON\2100  
 TRAVIS\LEVEL\_41\20180920\F047.dwg

CLIENT APPROVAL  
 APPROVED  
 APPROVED AS NOTED  
 REVISE AND RESUBMIT  
 APPROVED BY/DATE:

LEGAL NOTICE:  
 DRAWING AND MATERIAL PRESENTED REMAIN THE PROPERTY OF CONTRACTOR RESIDENCY GROUP AND MAY NOT BE DUPLICATED, USED OR DISCLOSED WITH THE CONSENT OF CONTRACTOR RESIDENCY GROUP. NOT FOR REGULATORY APPROVAL, PERMITTING OR CONSTRUCTION. DUE TO CITY CODES ON NEW CONSTRUCTION, ALL ELECTRIFICATION OF INTERNAL FURNITURE PRODUCT MUST BE PERFORMED BY A LICENSED ELECTRICIAN AND RETENTION OF SAME IS THE CLIENT'S RESPONSIBILITY.

7108 Old Katy Rd., Suite 150  
 Houston, TX 77024  
 Phone: 713-869-0500  
 www.crgoffice.com

ALL 1/16" = 1'-0"  
 DESIGNER: KERRY BALLESTY  
 ARCHITECT: RANDI SCHRAMM



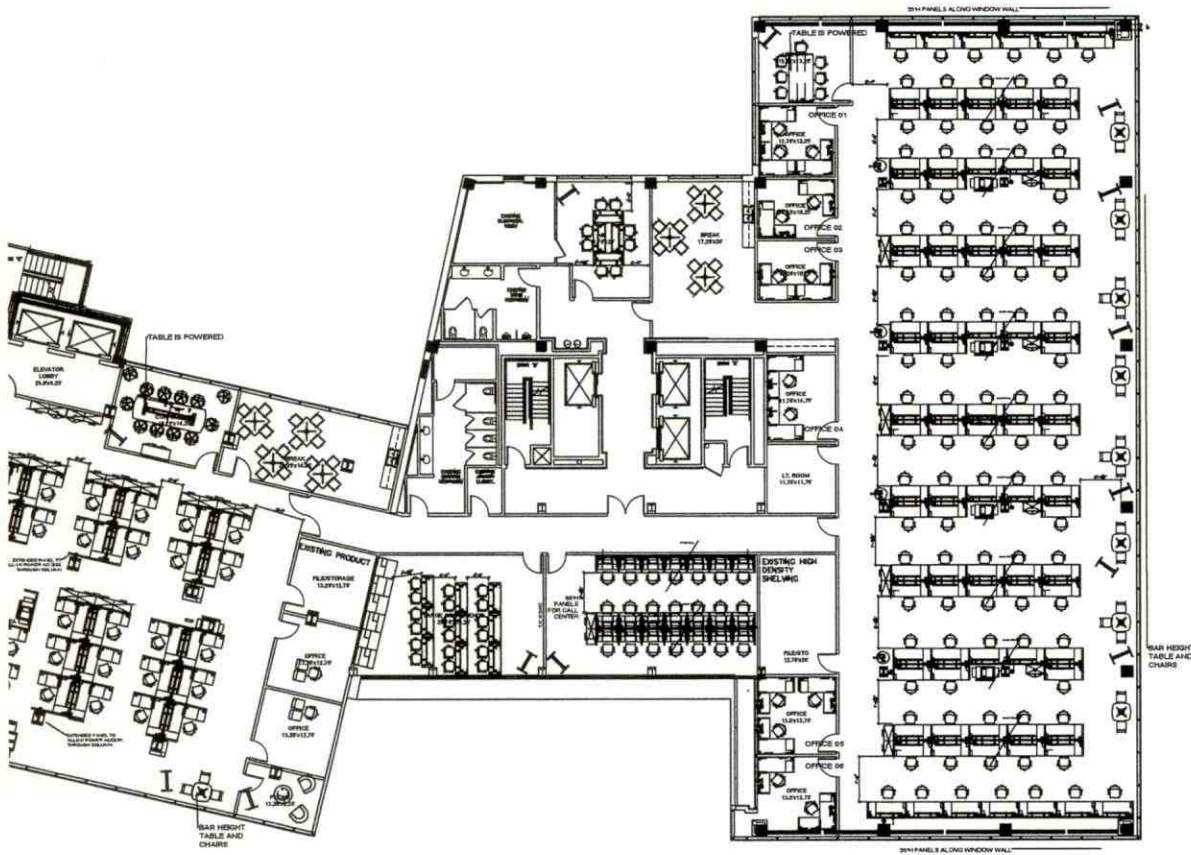

CITY OF HOUSTON

PROJECT INFO  
600 TRAVIS ST  
LEVEL 04

ALL SCALE TO FIT  
DATE 7.17.2018  
DESIGNER KERRY BALLESTY  
ACCT MGR RANDI SCHRAMM

PROPOSED FURNITURE PLAN  
EAST SIDE

FILE PATH / NAME  
G:\CAP PROJECTS 2018\CITY OF HOUSTON\2100  
TRAVIS\LEVEL 04\828009FD4F.dwg

LEGAL NOTICE:  
DRAWING AND MATERIAL PRESENTED REMAIN THE PROPERTY OF CONTRACTOR RESOURCE GROUP AND MAY NOT BE REPRODUCED, USED OR DISCLOSED WITH THE CONSENT OF CONTRACTOR RESOURCE GROUP, NOT FOR REGULATORY APPROVAL, PERMITTING OR CONSTRUCTION. DUE TO CITY CODE ON NEW CONSTRUCTION, ALL ELECTRIFICATION OF EXISTING FURNITURE PRODUCT MUST BE PERFORMED BY A LICENSED ELECTRICIAN AND RETENTION OF SAME IS THE CLIENT'S RESPONSIBILITY.

CLIENT APPROVAL  
 APPROVED  
 APPROVED AS NOTED  
 REVISE AND RESUBMIT  
 APPROVED BY/DATE:



7108 Old Katy Rd., Suite 150  
Houston, TX 77024  
Phone: 713-603-0300  
www.crgoffice.com



# City of Houston

Tenant Interior Build-Out

SPECIFICATIONS

City of Houston  
Department of General Services  
2100 Travis Street, Houston, TX 77002  
713.251.2000

**COH Tenant Interior Build-out Specifications**  
**Exhibit “ “**

May 21, 2018  
General Services Department

Housing and Community Department (HCD)  
2100 Travis Houston, TX  
4<sup>th</sup> floor

- All specifications will pertain to the space plans submitted to the landlord.
- Contractor to abide by all current City, State and Federal Codes for the build out of the space.
- Contractor to permit all drawing and submit to City of Houston Code Enforcement and TAS for approval.
- Contractor to provide environmentally responsible practices that minimizes adverse effects on the exterior environment, enhances the quality of the indoor environment, and minimizes consumption of energy, water, construction materials, and other resources.
- Contractor to submit a set of complete plans to tenant for approval prior to submitting for permit for verification of all information.

**I. DOORS**

**Number & location of doors to be designated by tenant.**

1. All new doors and frames to be uniform to match throughout existing suite. Hardware to meet all ADA specifications.
2. All door hardware to include locks for securing office space. Landlord to provide keys and at least two master keys.
3. Install panic hardware on egress doors as needed per code.
4. Provide/install door closers at all suite, reception, storage and conference room areas. Provide and install door stops for all doorways.
5. Provide door vision panels at all lobby, and suite room areas.
6. Provide a lock on all entry & storage room doors. Computer room to have dead bolt lock. Lactation room to receive occupancy indicator deadbolt.
7. Door electric strike: ROFU 2400, stainless steel

**II. WINDOWS**

Mini blinds or equivalent building standard window coverings to be provided on all windows.

### III. INTERIOR WALL

1. Provide insulation in all Conference, Multi-purpose, Copy/Plotter, and Huddle/Quiet Rooms and extend walls up to deck.
2. Provide insulation in Restroom walls and extend walls up to deck.
3. Provide and install chair railing on conference room and waiting room walls.
4. Provide wall blocking in all IT closets, Conference and Multipurpose Rooms to support wall mounted equipment or monitor screens. Refer to plans for locations.

### IV. FINISHES

#### WALLS:

**Sample to be submitted for approval for any paint color selection.**

1. All existing walls to receive one or more coats of paint as required to restore to new condition prior to move-in. Any existing or damage walls are to be repaired and painted to match new finishes. Sherwin Williams Paint or equal with low VOC rating. **Paint samples to be submitted for approval.**
2. Drywall finish at new walls to receive a level 4 finish
3. All existing corridors to receive new paint

#### FLOORING:

**Sample to be submitted for approval for any new flooring required.**

1. Install new rubber cove base at all new walls.
2. All VCT existing areas to be stripped and waxed. A minimum of 4 coats of wax to be applied prior to move in unless VCT specs state differently.

#### CEILING:

1. Open concept.
2. Minimum .75 NRC acoustical performance criteria for sound control in open plan areas.

### V. SIGNAGE

**Tenant's chosen vendor to submit sign for approval by City and Landlord.**

1. Signs are to be furnished and installed by Contractor.

### VI. MILLWORK

**Length & location of cabinetry to be designated by tenant. Refer to plans.**

1. Provide Break room and kitchenettes with plastic laminate counter with prefab (ready-made) base and wall cabinets.

#### VII. SYSTEMS FURNITURE

1. Systems Furniture to be furnished per Tenant.
2. Contractor to coordinate with Systems Furniture vendor.
3. Contractor to follow General Specifications as per City provided specifications.

#### VIII. ELEVATOR

1. Provide ADA elevator, where required, with access to all occupied levels. Elevator must meet ADA requirements.

#### IX. FIRE PROTECTION

1. Provide Fire sprinkler system throughout the entire space with the system in the computer room (where applicable) to be a preaction type.

#### X. PLUMBING

1. Provide Break rooms, kitchenettes, and lactation rooms with stainless steel sink with hot & cold water.
2. Provide all restroom fixtures, and drinking fountains, to comply with ADA, in numbers meeting current building codes.

#### XII. HVAC

##### THERMAL PERFORMANCE:

Provide heating & cooling system to condition the space to the following criteria:

Summer: Cool to 75 degrees with design condition of 92 degrees dry bulb/ 76 degrees wet bulb

Winter: Heat to a minimum of 70 degrees with a design condition of 0 degrees outside air temperature.

1. Contractor to verify that all HVAC units are functioning properly.
2. Re-work all duct (return and supply) as needed to satisfy new floor plan.
3. Verify all thermostats are working properly. Relocate as needed.
4. All electrical and plumbing to be installed for HVAC equipment to meet all City and State codes.

#### XIII. ELECTRICAL

**Tenant to review and approve final electrical floors plans prior to plan submittal.**



LIGHTING: Provide recommended lighting power densities and energy performance criteria in accordance to the current code: 2015 IECC.

POWER:

- Work stations: Power connection to panel system with a capacity of 1 circuit per 3 work stations and empty conduit with a capacity for 2 data/comm. cables per work station.  
Stations to be powered off of a wall or column where applicable, floor boxes if in the center of an open area; no power poles unless with Tenants prior written approval.
- Medium Offices: (up to 150 sq. ft.) 2 standard electrical duplex outlets & 1 empty box for data/comm. cables.
- Large Offices: (over 150 sq. ft.) 3 standard electrical duplex outlets & 1 empty box for data/comm. cables.
- Lg. Conference Rm. (over 500 sq. ft.) 6 standard electrical duplex outlets and, 4 empty boxes for data/comm. cables.; 1 centrally located floorbox
- Multipurpose Rm: 10 standard electrical duplex and 4 empty boxes for data/comm. cables.
- Other Conferences: 3 standard electrical duplex outlets & 1 empty box for data/comm. cables.
- Provide power and an empty box for data/comm. cable to each copier, printer, and fax machine.
- Reception area: 4 standard duplex elec, 1 data/comm.
- Lactation room: 1 standard duplex
- General Purpose: Provide convenience and cleaning outlets to be able to reach using a maximum of a 50' appliance cord.

1. Contractor to verify electrical service and panel capacity is adequate.
2. Contractor to run and tie in all electrical whips for modular furniture per code. Furniture vendor is only responsible for providing electrical components.
3. All new outlets to be installed at heights and locations per code.
4. Verify electrical outlet locations per offices receiving system furniture.
5. Provide life safety horn/strobes/alarm system as required by building code.
6. Provide Exit signs and emergency lighting as required by building code.
7. Provide electrical wiring runs at access control card-swipe entries.

#### XIV. PHONE AND DATA

**All cable & wiring for telephones & computers is excluded; or performed by Landlord per Tenant's specifications and reimbursed by Tenant.**

\*Refer to the City of Houston IT Telecommunications Cabling System Standards (dated June 25, 2015)

1. Landlord to provide phone service to the phone room to be used by the Tenant.
2. Contractor is responsible for providing empty data box and pull string.

#### XV. SECURITY

Landlord to coordinate with City of Houston Security for tenant floor access control system. Landlord is responsible for the installation of all security devices.

**City of Houston Security to review and approve security/electrical drawings.**

**City of Houston Security to inspect security systems post construction.**

1. Tenant to identify card-reader and ceiling mounted camera locations.

\*Refer to the City of Houston standard security devices product specifications (dated January 19, 2018)

Exhibit "D-2"

## Exhibit "D-2"

### Work Letter

This Work Letter (this "Agreement") is made and entered into this \_\_\_\_\_ day of \_\_\_\_\_, 2018, in connection with that certain Lease Agreement (the "Lease") by and between, **MIDTOWN CENTRAL SQUARE, LLC.**, a Texas limited liability company, as Landlord ("Landlord"), and **THE CITY OF HOUSTON, TEXAS**, a municipal corporation situated in Harris, Fort Bend and Montgomery Counties, as Tenant ("Tenant"), and, together with the Lease, constitutes the entire agreement between Landlord and Tenant with respect to the construction and completion of the improvements in and to Leased Premises. All capitalized terms used herein, but not defined herein, shall have the meanings ascribed to such terms in the Lease.

To induce Landlord and Tenant to enter the Lease (which is incorporated herein by reference to the extent that its provisions may apply hereto) and in consideration of the mutual covenants hereinafter contained, Landlord and Tenant mutually agree as follows:

1. Construction Plans. Tenant has provided to Landlord the specifications and space plans for the Leased Premises attached as **Exhibit "D1"** to the Lease (the "Tenant Specifications"). Landlord will provide, by Landlord's designated "Architect" and/or "Engineer," and at Landlord's sole cost and expense, the following "Construction Plans," based upon the Tenant Specifications provided by Tenant and drawn for the Leased Premises on Tenant's behalf:
  - a. Completed, finished, cable locations and detailed architectural drawings for Tenant's partition layout, ceiling, telephone and electrical outlets, and for the work to be done by Landlord under Paragraph 2 hereof;
  - b. Completed plans, where necessary, for installation of air-conditioning grilles and registers, heating, plumbing and electrical facilities for the work to be done by Landlord under Paragraph 2 hereof.

The work required to be performed pursuant to the Construction Plans shall be referred herein to as "Landlord's Work."

When such draft Construction Plans have been completed, Landlord shall promptly deliver them or cause them to be delivered to Tenant. If Tenant has any objections or comments with respect to such draft Construction Plans, Tenant shall notify Landlord of such objections within four (4) business days after receipt of the draft Construction Plans. Tenant's failure to provide the foregoing notification shall be deemed as Tenant's approval of such draft Construction Plans. Landlord, at Landlord's sole cost and expense, shall cause the Architect and/or Engineer to make the requested changes and modifications to the draft Construction Plans that

are approved by Landlord (such approval not to be unreasonably withheld, delayed or conditioned), and shall resubmit to Tenant the modified Construction Plans, which shall be subject to the same review, approval and modification procedures set forth above. Notwithstanding the foregoing, if Tenant requires additional modifications to the Construction Plans after the second revision, such additional modifications shall be at Tenant's sole cost and expense, and each day of delay caused by such additional round of modifications shall be considered one (1) day of Delay (hereinafter defined). The agreed-upon Construction Plans shall be hereinafter referred to as the "Final Plans." The parties must agree upon the Final Plans before the Construction Plans are submitted for building permits.

Landlord, at its sole cost and expense, will cause the Final Plans to be filed with the appropriate governmental agencies in such form (building notice, alteration or other form) as may be required.

2. Landlord's Work. Landlord agrees to perform, at its sole cost and expense (except as otherwise expressly provided herein), Landlord's Work in the Leased Premises, said work to be commenced after Tenant has approved in writing (or has been deemed to approve) the Final Plans. Landlord's Work required to be performed pursuant to the Construction Plans shall include the following:

a. Partitioning. Landlord will furnish and install partitioning in place in accordance with the Tenant Specifications reflected on **Exhibit "D-1"**.

b. Painting. Landlord will paint all interior partitions with one (1) primer and two (2) finish coats in accordance with the Tenant Specifications reflected on **Exhibit "D-1"**.

c. Doors, Frames and Hardware. Landlord will furnish and install doors and door frames, including corridor door(s) required by City of Houston Building or Fire Codes, in accordance with the Tenant Specifications reflected on **Exhibit "D-1"**.

d. Electrical Outlets. Landlord will furnish and install electrical outlets in accordance with the Tenant Specifications reflected on **Exhibit "D-1"**.

e. Telephone Outlets. Landlord will provide for the installation of wall-mounted telephone outlets in accordance with the Tenant Specifications reflected on **Exhibit "D-1"**.

f. Light Fixtures. Landlord will furnish and install light fixtures in accordance with the Tenant Specifications reflected on **Exhibit "D-1"**.

g. Light Switches. Landlord will furnish and install wall switches in each designated office/conference room/storage room/break area in accordance with the Tenant Specifications reflected on **Exhibit "D-1"**.

h. Ceiling. Landlord will furnish and install ceiling throughout in accordance with the Tenant Specifications reflected on **Exhibit "D-1"**.

i. Flooring. Landlord will furnish and install floor treatments in accordance with the Tenant Specifications. Landlord shall provide base building carpet at a cost under no circumstances to exceed \$\_\_\_\_/yard. Any cost in excess \$\_\_\_\_/yard for such carpeting shall be the sole responsibility of Tenant and shall be paid to Landlord prior to the commencement of Landlord's Work.

j. Window Covering. Landlord will furnish and install mini-blinds on all exterior windows in accordance with the Tenant Specifications reflected on **Exhibit "D1"**.

k. Heating, Ventilation and Air-Conditioning. Landlord will ensure that the HVAC system in place on the Occupancy Date is in good working order so that it will perform its intended function and will satisfactorily service the Leased Premises as of the Occupancy Date. The cost of the inspection and, if appropriate, repair or upgrading before the Occupancy Date will be borne by Landlord.

l. Plumbing. Landlord will furnish and install plumbing in accordance with the Tenant Specifications reflected on **Exhibit "D1"**.

3. Tenant's Right to Enter Premises to Perform Work. Landlord will permit Tenant and its agents reasonable access to the Leased Premises during normal working hours prior to the date specified for the commencement of Tenant's occupancy under the Lease, in order that Tenant may perform through its own contractors such work and decorations as Tenant may desire at the time that Landlord's contractors are working in the Leased Premises. The foregoing license to enter prior to the commencement of the Lease Term, however, is conditioned upon Tenant's workmen and mechanics working in harmony and not interfering with any person employed by Landlord, Landlord's mechanics or contractor or by any other tenant or that tenant's contractor. Any delay to Landlord's Work caused by Tenant's work at this time will be deemed Delay and will be treated as such as provided for in this Work Letter. Such license is further conditioned upon workmen's compensation and public liability insurance and property damage insurance, all in amounts and with companies and on forms satisfactory to Landlord, being provided and at all times maintained by Tenant's contractors engaged in the performance of the work, and certificates of such insurance being furnished to Landlord prior to proceeding with the work. If at any time such entry shall cause disharmony or interference with Landlord's agents, employees, mechanics or contractors, this license may be withdrawn by Landlord upon forty-eight (48) hours written notice to Tenant. Such entry shall be deemed to be subject to all of the terms, covenants, provisions and conditions of said Lease except as to the covenant to pay Rent. Landlord shall not be liable in any way for any injury, loss or damage which may occur to Tenant, its employees, contractors, agents, workmen and mechanics, or any one or more of them, or to any of Tenant's decorations or installations so made prior to commencement of the Lease Term, the same being solely at Tenant's risk, and Tenant hereby agrees to hold Landlord harmless from any and all claims therefor or arising therefrom.

4. Inspection of Tenant's Work. Landlord and its agents may, at any time inspect any of Tenant's work performed under Section 3 of this Work Letter, to ensure that such work is of acceptable quality and does not conflict with the Final Plans. To the extent that any of Tenant's work is not of an acceptable quality and/or conflicts with the Final Plans, Tenant shall immediately cease such work and at Tenant's sole cost and expense repair or replace the same, as reasonably required by Landlord.

5. Negation of Landlord's Warranties. Except for Landlord's warranties set forth in the Lease, LANDLORD MAKES NO WARRANTIES, EXPRESS OR IMPLIED, INCLUDING, WITHOUT LIMITATION, IMPLIED WARRANTIES OF MERCHANTABILITY AND FITNESS FOR A PARTICULAR PURPOSE, IN CONNECTION WITH THE LANDLORD'S WORK OR ANY OTHER IMPROVEMENTS MADE TO THE LEASED PREMISES OR THE PROJECT. Tenant will also hold Landlord and its property manager and agents harmless from and against any claim, cost, damage, suit, or liability in respect of any damage or injury to any person arising from any construction activities engaged in by Tenant or any agent or independent contractor thereof (or by any agent or sub-contractor of any such party) other than caused by the gross negligence or willful misconduct of Landlord.

6. For the purposes of this Work Letter and the Lease, the terms "Substantial Completion" or "Substantially Completes" or any similar expression of like import shall mean when (a) the Landlord Work to be performed by Landlord has been completed in accordance with this Work Letter, the Lease, and the Final Plans, except for normal and typical punch list items which do not adversely affect Tenant's use or occupancy of the Leased Premises in any material respect, and (b) Landlord has delivered (or caused to be delivered) to Tenant a Certificate of Occupancy for the Leased Premises from the governmental authority which has authority to issue such certificates in the City of Houston, Texas.

7. For the purposes of this Work Letter and the Lease, "Delay" shall mean any actual delay experienced by Landlord or its developer or contractors in substantially completing the Landlord's Work resulting from Tenant's actions or inactions including, without limitation:

(a) Tenant's failure to complete any action or item or give approval or comments on or before the due date, which is the responsibility of Tenant, pursuant to the schedules set forth herein; or

(b) Tenant's request for materials, finishes or installations, other than building standard items for the Leased Premises or the Project, which require lead times greater than those required for building standard items or changes to the Final Plans which are incompatible with the design, construction or equipment of the Leased Premises or the Project; or

(c) Any event expressly identified as Delay in this Work Letter or the Lease.

Each day of delay caused by any of the foregoing shall be considered one (1) day of Delay for the purposes of determining the Occupancy Date under the Lease.

8. Both Parties acknowledge that it is Tenant's intent to occupy the Leased Premises on or before March 1, 2019. Accordingly, notwithstanding any provision in the Lease otherwise to the contrary, when Landlord Substantially Completes all of Landlord's Work as described above and delivers the Leased Premises to Tenant, Tenant will execute the Certificate of Commencement and commence paying Rent as specified in the Lease. In all other events, the terms of the Lease shall control.

"LANDLORD"

"TENANT"

MIDTOWN CENTRAL SQUARE, LLC

CITY OF HOUSTON, TEXAS

By: \_\_\_\_\_

By: \_\_\_\_\_

Print name: \_\_\_\_\_

C.J. Messiah, Jr. - Director

Position: \_\_\_\_\_

General Services Department